 **OMT3-OMT4 CATALOGUE**
 **IE1 - IE3 - IE4**



OMEC MOTORS to jeden z największych niezależnych producentów i dystrybutorów silników elektrycznych w Europie. Firma wchodzi w skład grupy PEJA istniejącej na rynku od 1937 roku. OMEC konstruuje, produkuje i dostarcza silniki elektryczne na całym świecie, a sieć dystrybutorów w ponad 60 krajach zapewnia wsparcie techniczne i sprzedażowe.

OMEC Motors is one of the largest independent manufacturers and distributors in Europe. The company is a member of PEJA Group established 1937. OMEC develops, manufactures and distributes electric motors on a global scale and has distributors in over 60 countries all over the world.

Dane dystrybutora/ Distributor data

General characteristics

This catalog includes three-phase low voltage squirrel cage motors of following series:

- OMT3 – cast iron series, frame size 80 - 355**
- OMT4 – aluminum series, frame size 56 - 160**

Motors are manufactured in ribbed frames in closed version IP55 with surface cooling (TEFC).

They are applicable to the general industry. They can be used to drive various machines and devices, whose operation is continuous, without frequent starts and direction reversals. Due to the degree of interior protection they can work in conditions, in which the surrounding air contains pollution. The dustiness of the environment should not be higher than 10 mg/m3. However, the pollution can not be chemically aggressive, such as acid vapors and alkali suds or explosive mixtures. The terminal box is in standard placed at the top of the engine block. Motors are designed for two-way operation.

Standards

The motors meets the requirements contained in the standards PN-EN 60034-1, IEC 34-1/9, PN-IEC 72-1, IEC 85, DIN 57530/VDE 0530 and in related and equivalent standards. Motors marked with IE2/IE3 symbols meet the requirements of the standard PN-EN 60034-30 and EC 640/2009 + UE4/2014 regulations regarding high efficiency electric motors according to IE2 and IE3 classification.

- Protection class: IP55 according to the PN-IEC 34-5 standard
- Cooling method: IC411 according to the PN-IEC 34-6 standard
- Mounting method: B3; B35; B5; B14; B34; V1 acc. PN-IEC 34-7 standard 34-7 standard

- Insulation class: F
- Temperature rise: B ($\leq 80\text{ }^{\circ}\text{C}$)
- Ambient air temperature range: -20 ... +40 $^{\circ}\text{C}$
- Installation height: <1000 m above sea level

Voltage and frequency

In the basic version, the motors are supplied for the following supply voltages:

- 230 V (Δ) / 400 V (Y) $\pm 5\%$; 50 Hz for a power of $\leq 2,2\text{ kW}$
- 400 V (Δ) / 690 V (Y) $\pm 5\%$; 50 Hz for a power of $\geq 3,0\text{ kW}$

Windings of the motors with power below 2.2 kW are initially connected to star connection (Y), while motors with powers above 3.0 kW are connected to a delta (Δ) - as a standard for a supply voltage of 400 V / 50 Hz.

The motors have 6 winding terminals, which allows them to be switched into a delta or star, depending on the available power source. For all motors with winding for 400V/690V voltage, it is possible to start the motor using the Δ/Y -switch.

Standard motors can also be supplied from the network with a nominal frequency of 60 Hz, whereby they gain the rated power higher by about 15% than when supplied by the 50 Hz network, respectively:

- 265 V (Δ) / 460 V (Y) $\pm 5\%$; 60 Hz $\rightarrow P_{60\text{ Hz}} = 115\% \times P_{50\text{ Hz}}$
- 460 V (Δ) / 796 V (Y) $\pm 5\%$; 60 Hz $\rightarrow P_{60\text{ Hz}} = 115\% \times P_{50\text{ Hz}}$

According to PN-EN 60034-1 and IEC34-1, it is also allowed to supply motors with a voltage tolerance of 10%, but then the parameters may deviate from the rated ones and allowable temperature increases of the windings may differ about 10 $^{\circ}\text{C}$ from the accepted values for a given class heat resistance.

Windings

Stator windings are made of high quality winding wires and insulation materials class F (155 $^{\circ}\text{C}$) while maintaining temperature increases corresponding to class B (not more than 80 $^{\circ}\text{C}$). It gives you the possibility of work with frequency converters (inverters) and applications in all climate zones. The motor winding is made of aluminum as a die-casting cage.

To protect the windings against excessive overheating PTC thermistors (Mark A) with nominal response temperature TNF = 150 $^{\circ}\text{C}$ (1 piece per phase) were used. The characteristics of PTC thermistors is compliant with the IEC 34.11-2 standard. To cooperate with PTC thermistors are recommended to use resistive relays with the Mark A characteristic.

Bearings

The motors of frame size 56 to 160 are additionally fitted as standard with closed ball bearing that do not require additional lubrication. In motors of frame sizes 180 to 355, open bearings with the possibility of relubrication during running were used.

Frame size	Number of poles	Drive side DE	Other side NDE
56-63	2,4	6201 2RS	6201 2RS
71	2,4,6	6202 2RS	6202 2RS
80	2,4,6,8	6204 2RS	6204 2RS
90	2,4,6,8	6205 2RS	6205 2RS
100	2,4,6,8	6206 2RS	6206 2RS
112	2,4,6,8	6306 2RS	6306 2RS
132	2,4,6,8	6308 2RS	6308 2RS
160	2,4,6,8	6309 2RS	6309 2RS
180	2,4,6,8	6311 C3	6311 C3
200	2,4,6,8	6312 C3	6312 C3
225	2,4,6,8	6313 C3	6313 C3
250	2,4,6,8	6314 C3	6314 C3
280	2	6314 C3	6314 C3
	4,6,8	6317 C3	6317 C3
315	2	6317 C3	6317 C3
	4,6,8	NU319	6319 C3
355	2	6319 C3	6319 C3
	4,6,8	NU322	6322 C3 7322B (V1)

On request, the motors can be equipped with reinforced cylindrical bearings of the Nxxx series, installed on the drive side. When using a belt drive or other gears impacting on the bearings and end of the shaft, the permissible radial and axial load must be determined.

Balancing

The rotors of the motors are dynamically balanced with the half of the key (wedge) in the driving shaft end. The balancing class complies with the international standard IEC 34-14: 1982, class N (normal).

Overload capacity and restart

According to the applicable standards, motors can be subjected to the following impact overloads:

- 1.5 x rated current within 2 minutes,
- 1.6 x nominal torque within 15 seconds.

Both conditions apply to rated supply conditions. In the event of a power failure, the motor can be restarted at full phase position and at 100% of the residual voltage.

Declaration of conformity, CE sign

The motors meet the requirements for quality standards and safety of use and are marked with the CE symbol. They are designed, manufactured and tested according to the ISO 9001 quality assurance system.

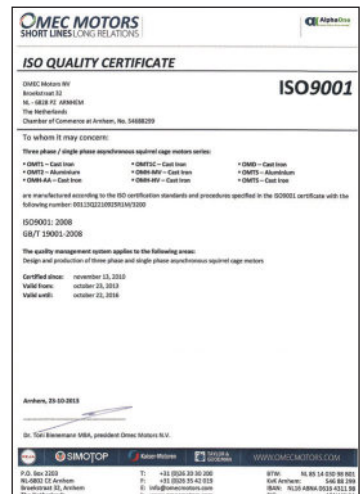

Motor type	Rated power	Rated speed	Rated current			Efficiency IE1	Power factor	Nominal torque	Locked-rotor torque	Break-down torque	Locked rotor current	Moment of inertia	Weight
	P_N	n_N	I_N			η	$\cos\phi$	M_N	M_R/M_N	M_{BRX}/M_N	I_R/I_N	J	m
	kW	min ⁻¹	A 230V	A 400V	A 690V	%	-	Nm	-	-	-	kgm ²	kg

2-pole motors – $n_s = 3000$ r/min

OMT4 56 1-2	0.09	2700	0.47	0.27		62.0	0.77	0.32	2.2	2.1	5.2	0.00018	3.8
OMT4 56 2-2	0.12	2700	0.60	0.35		64.0	0.78	0.42	2.2	2.1	5.2	0.00023	4.0
OMT4 56 C-2 *	0.18	2720	0.87	0.50		65.0	0.80	0.63	2.2	2.2	5.5	0.00025	4.1
OMT4 63 1-2	0.18	2720	0.87	0.50		65.0	0.80	0.63	2.3	2.3	5.5	0.00031	4.5
OMT4 63 2-2	0.25	2720	1.14	0.66		68.0	0.81	0.88	2.3	2.3	5.5	0.00039	4.7
OMT4 63 C-2 *	0.37	2755	1.66	0.96		69.0	0.81	1.28	2.3	2.2	6.1	0.00043	5.0
OMT4 71 1-2	0.37	2755	1.66	0.96		69.0	0.81	1.28	2.2	2.3	6.1	0.00060	6.0
OMT4 71 2-2	0.55	2790	2.37	1.36		71.0	0.82	1.88	2.3	2.3	6.1	0.00063	6.3
OMT4 71 C-2 *	0.75	2840	3.0	1.7		72.1	0.83	2.52	2.2	2.3	6.1	0.00065	6.8
OMT4 80 1-2	0.75	2845	3.1	1.8		72.1	0.83	2.52	2.3	2.2	6.1	0.00080	10
OMT4 80 2-2	1.1	2845	4.4	2.5		75.0	0.84	3.69	2.3	2.2	6.9	0.00087	11
OMT4 80 C-2 *	1.5	2850	5.8	3.3		77.2	0.84	5.03	2.2	2.3	7.0	0.00097	13
OMT4 90S-2	1.5	2850	5.8	3.3		77.2	0.84	5.03	2.3	2.2	7.0	0.0013	13
OMT4 90L-2	2.2	2855	8.2	4.7		79.7	0.85	7.36	2.3	2.2	7.0	0.0014	14
OMT4 90C-2 *	3.0	2860		6.1	3.5	81.5	0.87	10.02	2.2	2.3	7.5	0.0015	19
OMT4 100L-2	3.0	2860		6.1	3.5	81.5	0.87	10.02	2.3	2.2	7.5	0.0030	24
OMT4 100C-2 *	4.0	2880		7.8	4.5	84.2	0.88	13.26	2.2	2.3	7.5	0.0031	23
OMT4 112M-2	4.0	2880		7.9	4.6	83.1	0.88	13.26	2.3	2.2	7.5	0.0056	28
OMT4 112C-2 *	5.5	2900		10.7	6.2	84.7	0.88	18.11	2.2	2.3	7.5	0.0059	33
OMT4 132S1-2	5.5	2900		10.7	6.2	84.7	0.88	18.11	2.3	2.2	7.5	0.0126	40
OMT4 132S2-2	7.5	2900		14.3	8.3	86.0	0.88	24.70	2.3	2.2	7.5	0.0136	43
OMT4 132C-2 *	9.2	2900		17.5	10.2	86.0	0.88	30.29	2.2	2.3	7.5	0.0140	54
OMT4 132CB-2 *	11	2930		20.4	11.8	87.6	0.89	35.85	2.2	2.3	7.5	0.0150	58
OMT4 160M1-2	11	2930		20.4	11.8	87.6	0.89	35.85	2.3	2.2	7.5	0.0438	83
OMT4 160M2-2	15	2930		27.4	15.9	88.7	0.89	48.89	2.3	2.2	7.5	0.0544	90
OMT4 160L-2	18.5	2930		33.2	19.3	89.3	0.90	60.30	2.3	2.2	7.5	0.0674	104

4-pole motors – $n_s = 1500$ r/min

OMT4 56 1-4	0.06	1300	0.38	0.22		56.0	0.70	0.44	2.1	2.0	4.0	0.00030	3.8
OMT4 56 2-4	0.09	1300	0.54	0.31		58.0	0.72	0.66	2.1	2.0	4.0	0.00040	4.0
OMT4 56 C-4 *	0.12	1310	0.73	0.42		57.0	0.72	0.87	2.1	2.1	4.5	0.00045	4.1
OMT4 63 1-4	0.12	1310	0.73	0.42		57.0	0.72	0.87	2.2	2.1	4.4	0.00050	4.5
OMT4 63 2-4	0.18	1310	1.03	0.59		60.0	0.73	1.31	2.2	2.1	4.4	0.00060	4.7
OMT4 63 C-4 *	0.25	1345	1.30	0.75		65.0	0.74	1.78	2.1	2.2	5.2	0.00065	5.0
OMT4 71 1-4	0.25	1345	1.30	0.75		65.0	0.74	1.78	2.2	2.1	5.2	0.0008	6.0
OMT4 71 2-4	0.37	1340	1.85	1.06		67.0	0.75	2.64	2.2	2.1	5.2	0.0013	6.3
OMT4 71 C-4 *	0.55	1380	2.60	1.50		71.0	0.76	3.81	2.4	2.3	5.5	0.0014	6.8
OMT4 80 1-4	0.55	1380	2.56	1.47		71.0	0.76	3.81	2.3	2.4	5.2	0.0018	10
OMT4 80 2-4	0.75	1390	3.4	2.0		75.0	0.76	5.19	2.3	2.3	6.0	0.0021	11
OMT4 80 C-4 *	1.1	1390	4.8	2.7		75.0	0.77	7.56	2.3	2.3	6.0	0.0024	11

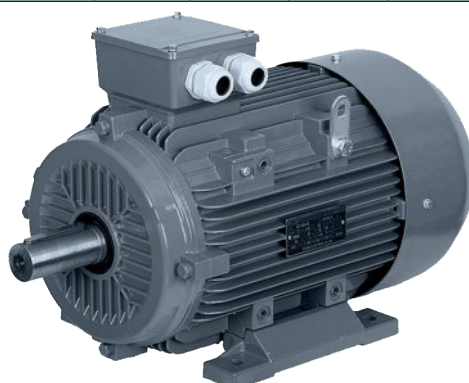

Motor type	Rated power	Rated speed	Rated current			Efficiency IE1	Power factor	Nominal torque ₁	Locked torque/ rated torque	Nominal torque	Locked current/ rated current	Moment of inertia	Weight
	P _N	n _N	I _N			η	cos φ	M _N	M _R /M _N	M _{MAX} /M _N	I _R /I _N	J	m
	kW	min ⁻¹	A 230V	A 400V	A 690V	%	-	Nm	-	-	-	kgm ²	kg

4-pole motors – n _s = 1500 r/min - continued													
OMT4 90C-4 *	2.2	1420	8.6	4.9		79.7	0.81	14.80	2.3	2.3	7.0	0.0029	17
OMT4 100L1-4	2.2	1420	8.5	4.9		79.7	0.81	14.80	2.3	2.3	7.0	0.0054	23
OMT4 100L2-4	3.0	1420		6.5	3.7	81.5	0.82	20.18	2.3	2.3	7.0	0.0067	25
OMT4 100C-4 *	4.0	1435		8.5	4.9	83.1	0.82	26.62	2.3	2.3	7.0	0.0072	25
OMT4 112M-4	4.0	1435		8.5	4.9	83.1	0.82	26.62	2.3	2.3	7.0	0.0095	29
OMT4 112C-4 *	5.5	1440		11.3	6.5	84.7	0.83	36.48	2.3	2.3	7.0	0.0103	33
OMT4 132S-4	5.5	1440		11.3	6.5	84.7	0.83	36.48	2.3	2.3	7.0	0.0214	43
OMT4 132M-4	7.5	1450		15.0	8.7	86.0	0.84	49.40	2.3	2.3	7.0	0.0296	55
OMT4 132C-4	9.2	1450		18.4	10.7	86.0	0.84	60.59	2.2	2.3	7.0	0.0320	57
OMT4 132CB-4 *	11	1460		21.6	12.5	87.6	0.84	71.95	2.2	2.3	7.0	0.0410	59
OMT4 160M-4	11	1460		21.6	12.5	87.6	0.84	71.95	2.3	2.3	7.0	0.0747	86
OMT4 160L-4	15	1460		28.7	16.6	88.7	0.85	98.12	2.3	2.3	7.0	0.0918	100

6-pole motors – n _s = 1000 r/min													
OMT4 71 1-6	0.18	870	1.22	0.70		56.0	0.66	1.98	1.9	2.0	4.0	0.0011	6.0
OMT4 71 2-6	0.25	870	1.56	0.90		59.0	0.68	2.74	1.9	2.0	4.0	0.0014	6.3
OMT4 80 1-6	0.37	880	2.14	1.23		62.0	0.70	4.02	1.9	2.0	4.7	0.0016	10
OMT4 80 2-6	0.55	880	2.95	1.70		65.0	0.72	5.97	1.9	2.1	4.7	0.0019	11
OMT4 80 C-6 *	0.75	900	3.74	2.15		70.0	0.72	7.96	2.0	2.0	5.2	0.0024	12
OMT4 90S-6	0.75	905	3.74	2.15		70.0	0.72	7.91	2.1	2.0	5.3	0.0029	13
OMT4 90L-6	1.1	905	5.19	2.98		72.9	0.73	11.61	2.1	2.0	5.5	0.0035	14
OMT4 90C-6 *	1.5	920	6.7	3.8		75.2	0.75	15.57	2.0	2.1	5.5	0.0038	15
OMT4 100L-6	1.5	920	6.7	3.8		75.2	0.75	15.57	2.1	2.0	5.5	0.0069	23
OMT4 100C-6 *	2.2	935	9.4	5.4		77.7	0.76	22.47	2.1	2.0	6.5	0.0075	28
OMT4 112M-6	2.2	935	9.4	5.4		77.7	0.76	22.47	2.1	2.0	6.5	0.0140	28
OMT4 112C-6 *	3.0	960		7.10	4.10	79.7	0.76	29.84	2.1	2.1	6.5	0.0152	33
OMT4 132S-6	3.0	960		7.15	4.14	79.7	0.76	29.84	2.1	2.1	6.5	0.0286	38
OMT4 132M1-6	4.0	960		9.33	5.41	81.4	0.76	39.79	2.1	2.1	6.5	0.0357	50
OMT4 132M2-6	5.5	960		12.4	7.19	83.1	0.77	54.71	2.1	2.1	6.5	0.0449	57
OMT4 132C-6 *	7.5	970		16.6	9.62	84.7	0.77	73.84	2.0	2.1	6.5	0.0509	62
OMT4 160M-6	7.5	970		16.6	9.62	84.7	0.77	73.84	2.1	2.0	6.5	0.0810	82
OMT4 160L-6	11	970		23.6	13.7	86.4	0.78	108.30	2.1	2.0	6.5	0.1160	93

8-pole motors – n _s = 750 r/min													
OMT4 80 1-8	0.18	645	1.45	0.84		51.0	0.61	2.67	1.9	1.8	3.3	0.0025	10
OMT4 80 2-8	0.25	645	1.91	1.10		54.0	0.61	3.70	1.9	1.8	3.3	0.0030	11
OMT4 90S-8	0.37	675	2.46	1.41		62.0	0.61	5.23	1.9	1.9	4.0	0.0051	13
OMT4 90L-8	0.55	680	3.57	2.06		63.0	0.61	7.72	2.0	1.9	4.0	0.0065	15
OMT4 90C-8 *	0.75	680	4.20	2.42		71.0	0.63	10.53	1.7	2.0	4.5	0.0078	23
OMT4 100L1-8	0.75	680	4.00	2.30		70.0	0.67	10.53	1.8	2.0	4.0	0.0095	23
OMT4 100L2-8	1.1	680	5.56	3.20		72.0	0.69	15.45	1.8	2.0	5.0	0.0109	25
OMT4 100C-8 *	1.5	690	7.30	4.22		74.0	0.70	20.76	1.8	2.0	5.0	0.0133	28
OMT4 112M-8	1.5	690	7.30	4.22		74.0	0.70	20.76	1.8	2.0	5.0	0.0245	28
OMT4 112C-8 *	2.2	710	9.80	5.70		79.0	0.71	29.59	1.8	2.0	6.0	0.0265	32
OMT4 132S-8	2.2	710	9.80	5.70		79.0	0.71	29.59	1.9	2.0	6.0	0.0314	40
OMT4 132M-8	3.0	710		7.40	4.30	80.0	0.73	40.35	2.0	2.0	6.0	0.0395	45
OMT4 132C-8 *	4.0	720		9.80	5.70	81.0	0.73	53.06	1.9	2.0	6.0	0.0427	52
OMT4 160M1-8	4.0	720		9.80	5.70	81.0	0.73	53.06	2.0	2.1	6.0	0.0753	71
OMT4 160M2-8	5.5	720		12.9	7.46	83.0	0.74	72.95	2.0	2.1	6.5	0.0931	83
OMT4 160L-8	7.5	725		16.9	9.77	85.5	0.75	98.79	2.0	2.0	6.5	0.1247	99

* - progressive motors

DIMENSIONAL DRAWING

Foot mounting B3

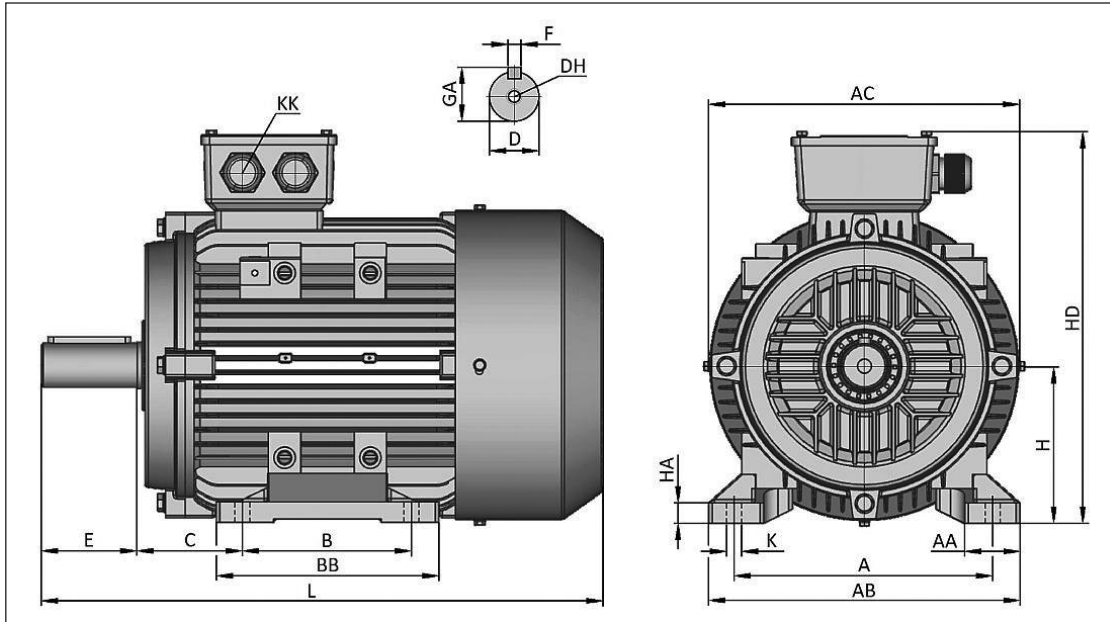

Motor type	A	B	C	D	E	F	GA	H	K	AA	AB	AC	BB	DH	HA	HD	KK	L
OMT4 56	90	71	36	9	20	3	10.2	56	6	23	115	112	88	M4×12	7	156	M20×1.5	201
OMT4 63	100	80	40	11	23	4	12.5	63	7	24	135	123	100	M4×12	7	172	M20×1.5	224
OMT4 71	112	90	45	14	30	5	16	71	7	26	150	136	110	M5×12	8	198	M20×1.5	247
OMT4 80	125	100	50	19	40	6	21.5	80	10	35	156	155	125	M6×12	9	214	M20×1.5	291
OMT4 90S	140	100	56	24	50	8	27	90	10	37	175	175	125	M8×19	10	230	M25×1.5	316
OMT4 90L.C	140	125	56	24	50	8	27	90	10	37	175	175	150	M8×19	10	230	M25×1.5	340
OMT4 100L.C	160	140	63	28	60	8	31	100	12	40	204	196	172	M10×22	11	260	M25×1.5	392
OMT4 112M.C	190	140	70	28	60	8	31	112	12	41	227	220	180	M10×22	12	290	M32×1.5	402
OMT4 132S	216	140	89	38	80	10	41	132	12	46	258	259	186	M12×28	15	338	M32×1.5	483
OMT4 132M.C	216	178	89	38	80	10	41	132	12	46	258	259	224	M12×28	15	338	M32×1.5	510
OMT4 160M	254	210	108	42	110	12	45	160	15	55	314	315	260	M16×36	18	415	M40×1.5	615
OMT4 160L	254	254	108	42	110	12	45	160	15	55	314	315	304	M16×36	18	415	M40×1.5	670

Foot & flange mounting B35
Flange mounting B5/V1

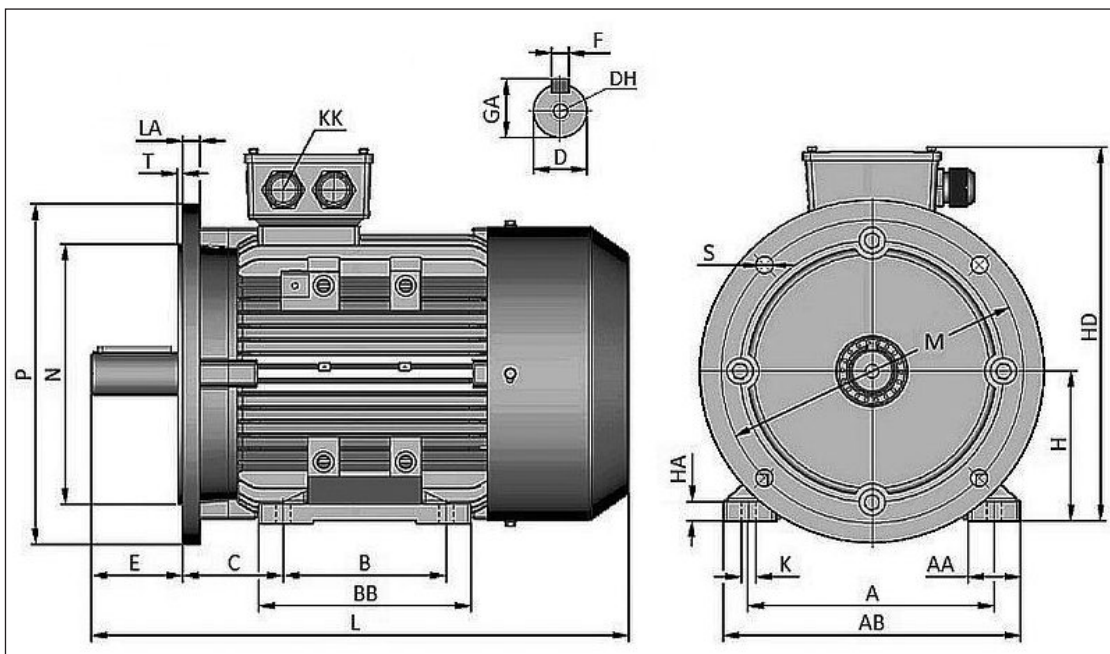

DIMENSIONAL DRAWING

Foot & flange mounting B34S, B34L
 Flange mounting B14S, B14L

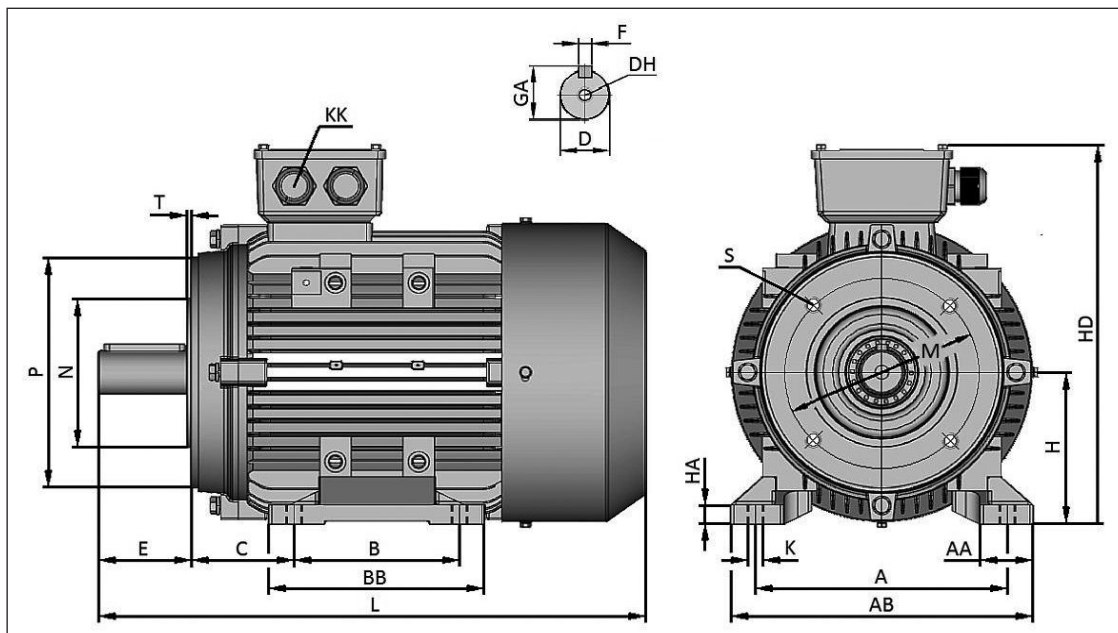

Motor type	A	B	C	D	E	F	GA	H	K	AA	AB	AC	BB	DH	HA	HD	KK	L
OMT4 56	90	71	36	9	20	3	10.2	56	6	23	115	112	88	M4×12	7	156	M20×1.5	201
OMT4 63	100	80	40	11	23	4	12.5	63	7	24	135	123	100	M4×12	7	172	M20×1.5	224
OMT4 71	112	90	45	14	30	5	16	71	7	26	150	136	110	M5×12	8	198	M20×1.5	247
OMT4 80	125	100	50	19	40	6	21.5	80	10	35	156	155	125	M6×12	9	214	M20×1.5	291
OMT4 90S	140	100	56	24	50	8	27	90	10	37	175	175	125	M8×19	10	230	M25×1.5	316
OMT4 90L.C	140	125	56	24	50	8	27	90	10	37	175	175	150	M8×19	10	230	M25×1.5	340
OMT4 100L.C	160	140	63	28	60	8	31	100	12	40	204	196	172	M10×22	11	260	M25×1.5	392
OMT4 112M.C	190	140	70	28	60	8	31	112	12	41	227	220	180	M10×22	12	290	M32×1.5	402
OMT4 132S	216	140	89	38	80	10	41	132	12	46	258	259	186	M12×28	15	338	M32×1.5	483
OMT4 132M.C	216	178	89	38	80	10	41	132	12	46	258	259	224	M12×28	15	338	M32×1.5	510
OMT4 160M	254	210	108	42	110	12	45	160	15	55	314	315	260	M16×36	18	415	M40×1.5	615
OMT4 160L	254	254	108	42	110	12	45	160	15	55	314	315	304	M16×36	18	415	M40×1.5	670

Dimensions of flanges

Motor type	B5						B14L					B14S				
	M	N	P	S	T	LA	M	N	P	S	T	M	N	P	S	T
OMT4 56	100	80	120	7	3	10	85	70	105	M6	2.5	65	50	80	M5	2.5
OMT4 63	115	95	140	10	3	10	100	80	120	M6	3.0	75	60	90	M5	2.5
OMT4 71	130	110	160	..	3.5	10	115	95	140	M8	3.0	85	70	105	M6	2.5
OMT4 80	165	130	200	12	3.5	12	130	110	160	M8	3.5	100	80	120	M6	3.0
OMT4 90S	165	130	200	12	3.5	12	130	110	160	M8	3.5	115	95	140	M8	3.0
OMT4 90L.C	165	130	200	12	3.5	12	130	110	160	M8	3.5	115	95	140	M8	3.0
OMT4 100L.C	215	180	250	15	4	13	165	130	200	M10	3.5	130	110	160	M8	3.5
OMT4 112M.C	215	180	250	15	4	14	165	130	200	M10	3.5	130	110	160	M8	3.5
OMT4 132S	265	230	300	15	4	14	215	180	250	M12	4.0	165	130	200	M10	3.5
OMT4 132M.C	265	230	300	15	4	14	215	180	250	M12	4.0	165	130	200	M10	3.5
OMT4 160M	300	250	350	19	5	15	-	-	-	-	-	-	-	-	-	-
OMT4 160L	300	250	350	19	5	15	-	-	-	-	-	-	-	-	-	-

OMT4-IE1 series motors have a monobloc frame structure with screwed feet and with threaded sprues on the frame, which makes it possible to extend the feet and change their location to the terminal box (variant with a terminal box on the right or the left side of the motor frame). By unscrewing or tightening the feet to the body you receive an other versions of the mechanical mounting method of the motor – respectively flange mounting (B5, B14) or foot & flange mounting (B35, B34).

Note: The manufacturer reserves the right to change the operating parameters and overall dimensions as the construction is modernized.

Motor type	Rated Power	Rated speed	Rated current			Efficiency IE3			Power factor	Nominal torque	Locked torque / rated torque	Max. torque / rated torque	Locked current / rated current	Moment of inertia	Weight
	P _N	n _N	I _N			η			cos φ	M _N	M _R /M _N	M _{MRX} /M _N	I _R /I _N	J	m
	kW	min ⁻¹	A 230V	A 400V	A 690V	% 4/4	% 3/4	% 1/2	- 4/4	Nm	-	-	-	kgm ²	kg

2-pole motors – nS = 3000 r/min															
OMT4-IE3 801-2	0,75	2890	2,85	1,64		80,7	81,0	79,3	0,82	2,48	2,3	2,3	7,0	0,00109	9,5
OMT4-IE3 802-2	1,1	2890	4,0	2,3		82,7	83,4	82,0	0,83	3,63	2,2	2,3	7,3	0,00142	10,5
OMT4-IE3 90S-2	1,5	2890	5,3	3,1		84,2	85,4	83,7	0,84	4,96	2,2	2,3	7,6	0,00217	16,0
OMT4-IE3 90L-2	2,2	2890	7,6	4,3		85,9	86,5	85,2	0,85	7,27	2,2	2,3	7,8	0,00283	20,0
OMT4-IE3 100L-2	3	2895		5,7	3,3	87,1	87,8	86,5	0,87	9,90	2,3	2,4	8,1	0,00457	26,0
OMT4-IE3 112M-2	4	2910		7,4	4,3	88,1	88,5	87,3	0,88	13,13	2,3	2,4	8,3	0,00631	33,5
OMT4-IE3 132S1-2	5,5	2940		10,1	5,9	89,2	89,5	88,4	0,88	17,87	2,1	2,3	8,3	0,01392	45,0
OMT4-IE3 132S2-2	7,5	2940		13,5	7,8	90,1	90,7	89,4	0,89	24,36	2,0	2,3	7,9	0,01643	51,0
OMT4-IE3 160M1-2	11	2950		19,6	11,3	91,2	91,4	89,9	0,89	35,61	2,0	2,3	8,1	0,0540	98,0
OMT4-IE3 160M2-2	15	2950		26,5	15,3	91,9	92,2	91,2	0,89	48,56	2,0	2,3	8,1	0,0618	108
OMT4-IE3 160L-2	18,5	2950		32,5	18,8	92,4	92,6	91,6	0,89	59,89	2,0	2,3	7,9	0,0716	128

4-pole motors – nS = 1500 r/min															
OMT4-IE3 80 2-4	0,75	1430	3,0	1,75		82,5	82,7	81,3	0,75	5,01	2,3	2,3	6,6	0,00270	12,5
OMT4-IE3 90S-4	1,1	1440	4,3	2,5		84,1	84,7	82,8	0,76	7,30	2,3	2,3	6,8	0,00327	15,5
OMT4-IE3 90L-4	1,5	1440	5,7	3,3		85,3	86,1	84,7	0,77	9,95	2,3	2,3	7,0	0,00414	19,0
OMT4-IE3 100L1-4	2,2	1455	7,9	4,5		86,7	87,2	85,7	0,81	14,44	2,3	2,4	7,6	0,00537	27,5
OMT4-IE3 100L2-4	3	1455		6,0	3,5	87,7	88,1	87,0	0,82	19,69	2,3	2,4	7,6	0,01012	32,0
OMT4-IE3 112M-4	4	1460		7,9	4,6	88,6	89,3	87,8	0,82	26,16	2,2	2,4	7,8	0,01392	39,0
OMT4-IE3 132S-4	5,5	1470		10,7	6,2	89,6	90,0	88,9	0,83	35,73	2,1	2,3	7,9	0,0310	55,5
OMT4-IE3 132M-4	7,5	1470		14,3	8,3	90,4	91,0	90,0	0,84	48,72	2,1	2,3	7,5	0,0398	65,0
OMT4-IE3 160M-4	11	1470		20,4	11,8	91,4	91,7	90,8	0,85	71,46	2,2	2,3	7,7	0,0852	108
OMT4-IE3 160L-4	15	1470		27,3	15,8	92,1	92,4	91,5	0,86	97,45	2,2	2,3	7,8	0,1116	127

6-pole motors – nS = 1000 r/min															
OMT4-IE3 90S-6	0,75	955	3,36	1,93		78,9	79,6	77,7	0,71	7,50	2,0	2,1	6,0	0,00414	16,0
OMT4-IE3 90L-6	1,1	955	4,7	2,7		81,0	81,8	79,8	0,73	11,00	2,0	2,1	6,1	0,00576	20,5
OMT4-IE3 100L-6	1,5	955	6,3	3,6		82,5	83,2	81,5	0,73	15,00	2,0	2,1	6,5	0,01164	26,5
OMT4-IE3 112M-6	2,2	970	8,9	5,1		84,3	84,6	82,9	0,74	21,66	2,0	2,1	6,6	0,01643	32,5
OMT4-IE3 132S-6	3	970		6,8	4,0	85,6	86,3	84,8	0,74	29,54	2,0	2,2	6,8	0,03459	45,0
OMT4-IE3 132M1-6	4	970		9,0	5,2	86,8	87,4	86,1	0,74	39,38	2,0	2,2	6,8	0,04286	56,5
OMT4-IE3 132M2-6	5,5	970		12,0	7,0	88,1	88,4	87,4	0,75	54,15	2,0	2,2	7,1	0,05374	63,0
OMT4-IE3 160M-6	7,5	980		15,4	8,9	89,1	89,5	88,4	0,79	73,09	2,0	2,1	7,0	0,04286	56,5
OMT4-IE3 160L-6	11	980		22,0	12,7	90,3	90,8	89,6	0,80	107,2	2,0	2,1	7,2	0,05374	63,0

8-pole motors nS = 750 r/min															
OMT4-IE3 90S-8	0,37	675	2,18	1,26		69,3	66,9	59,1	0,61	5,23	1,9	1,8	4,0	0,0051	15,0
OMT4-IE3 90L-8	0,55	680	3,08	1,78		73,0	70,6	63,6	0,61	7,72	2,0	1,8	4,1	0,0065	17,2
OMT4-IE3 100L1-8	0,75	680	3,72	2,15		75,0	73,8	67,9	0,67	10,53	2,0	1,8	4,2	0,0095	26,5
OMT4-IE3 100L2-8	1,1	680	5,12	2,96		77,7	78,2	73,8	0,69	15,45	2,0	1,8	5,1	0,011	29,0
OMT4-IE3 112M-8	1,5	690	6,71	3,88		79,7	79,5	75,6	0,70	20,76	2,0	1,8	5,3	0,0245	32,5
OMT4-IE3 132S-8	2,2	710	9,44	5,46		81,9	81,8	79,0	0,71	29,59	2,0	1,8	6,0	0,0314	46,0
OMT4-IE3 132M-8	3,0	710		7,10	4,10	83,5	82,6	80,3	0,73	40,35	2,0	1,8	6,2	0,0395	52,0
OMT4-IE3 160M1-8	4,0	720		9,33	5,39	84,8	83,8	82,6	0,73	53,06	2,0	1,9	6,3	0,0753	89,0
OMT4-IE3 160M2-8	5,5	720		12,45	7,20	86,2	85,9	84,3	0,74	72,95	2,0	2,0	6,6	0,0931	103



DIMENSIONAL DRAWING

Foot mounting B3

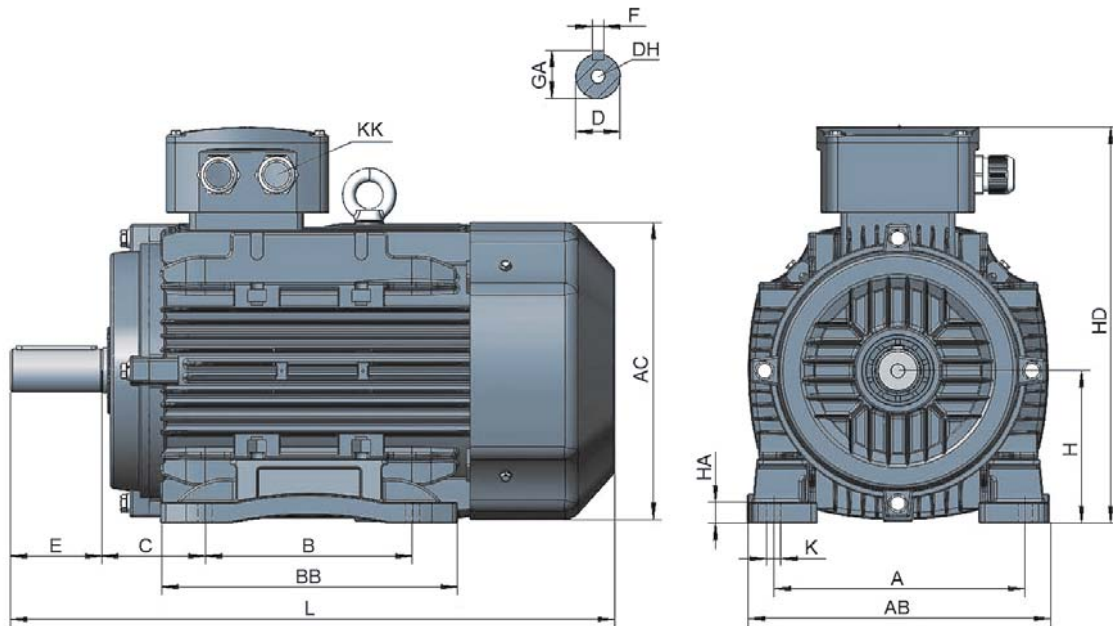

Motor type	A	B	C	D	E	F	GA	H	K	AB	AC	BB	DH	HA	HD	KK	L
OMT4-IE3 80	125	100	50	19	40	6	21.5	80	12×10	165	156	130	M6×16	9	218	M25×1.5	300
OMT4-IE3 90S	140	100	56	24	50	8	27	90	12×10	180	177	140	M8×19	10	241	M25×1.5	353
OMT4-IE3 90L	140	125	56	24	50	8	27	90	12×10	180	177	170	M8×19	10	241	M25×1.5	373
OMT4-IE3 100L	160	140	63	28	60	8	31	100	16×12	205	197	190	M10×22	11	280	M25×1.5	433
OMT4-IE3 112M	190	140	70	28	60	8	31	112	16×12	230	218	200	M10×22	15	293	M32×1.5	461
OMT4-IE3 132S	216	140	89	38	80	10	41	132	16×12	260	258	216	M12×28	18	344	M32×1.5	499
OMT4-IE3 132M	216	178	89	38	80	10	41	132	16×12	260	258	256	M12×28	18	344	M32×1.5	521
OMT4-IE3 160M	254	210	108	42	110	12	45	160	19×15	314	315	260	M16×36	18	415	M40×1.5	660
OMT4-IE3 160L	254	254	108	42	110	12	45	160	19×15	314	315	304	M16×36	18	415	M40×1.5	730

Foot & flange mounting B35
Flange mounting B5/V1

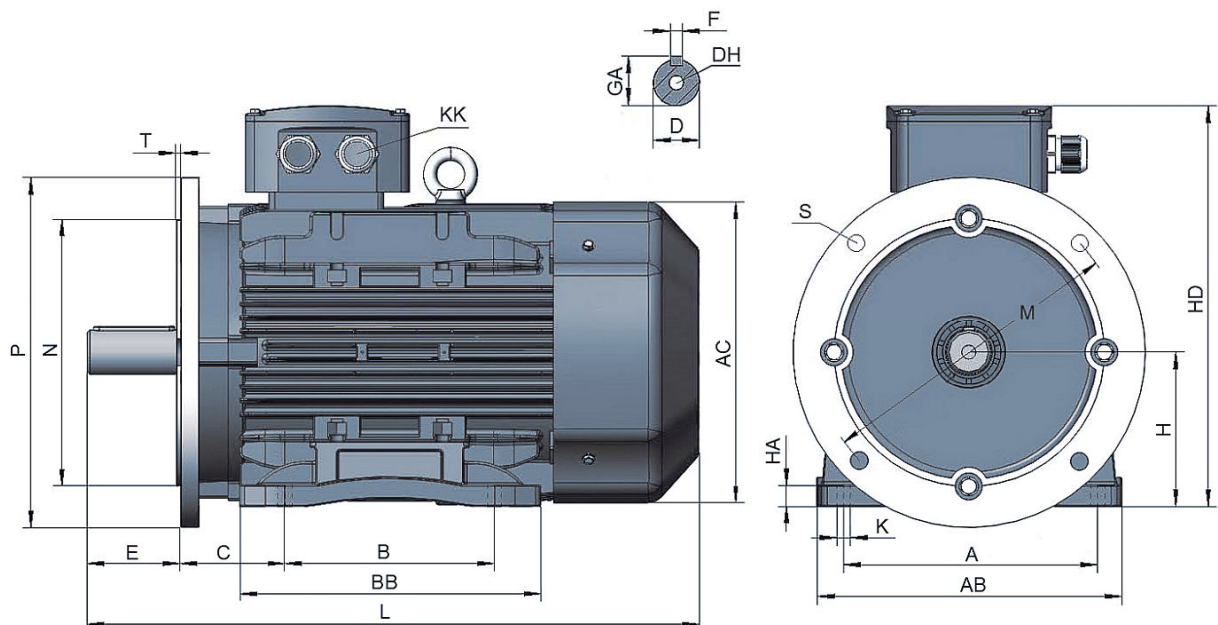

DIMENSIONAL DRAWING

Foot & flange mounting B34S, B34L
Flange mounting B14S, B14L

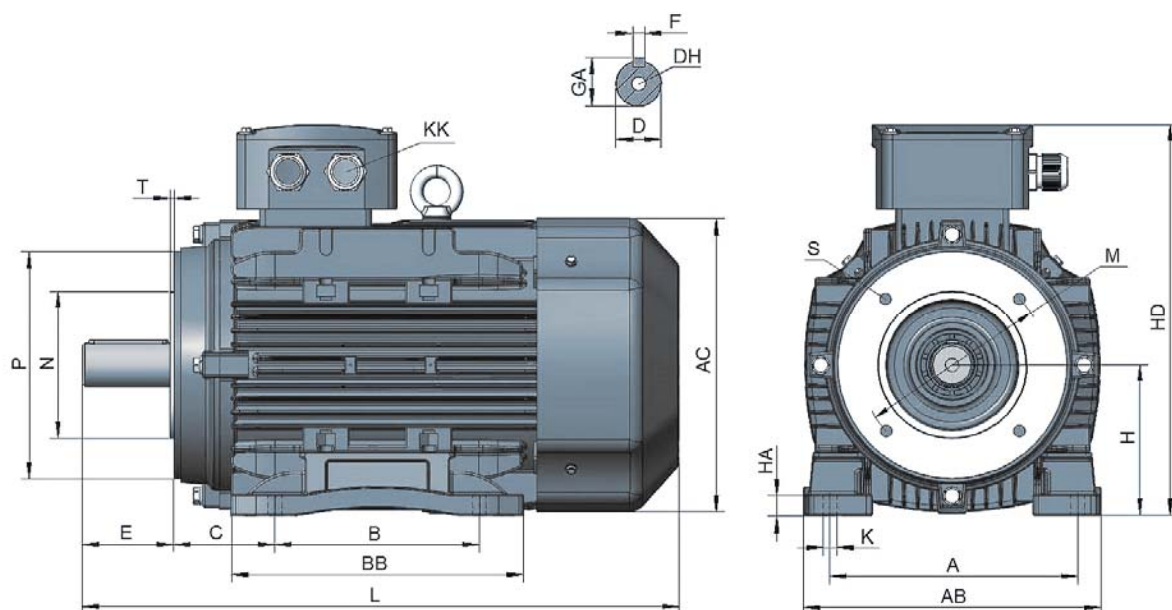

Motor type	A	B	C	D	E	F	GA	H	K	AB	AC	BB	DH	HA	HD	KK	L
OMT4-IE3 80	125	100	50	19	40	6	21,5	80	12×10	165	156	130	M6×16	9	218	M25×1,5	300
OMT4-IE3 90S	140	100	56	24	50	8	27	90	12×10	180	177	140	M8×19	10	241	M25×1,5	353
OMT4-IE3 90L	140	125	56	24	50	8	27	90	12×10	180	177	170	M8×19	10	241	M25×1,5	373
OMT4-IE3 100L	160	140	63	28	60	8	31	100	16×12	205	197	190	M10×22	11	280	M25×1,5	433
OMT4-IE3 112M	190	140	70	28	60	8	31	112	16×12	230	218	200	M10×22	15	293	M32×1,5	461
OMT4-IE3 132S	216	140	89	38	80	10	41	132	16×12	260	258	216	M12×28	18	344	M32×1,5	499
OMT4-IE3 132M	216	178	89	38	80	10	41	132	16×12	260	258	256	M12×28	18	344	M32×1,5	521
OMT4-IE3 160M	254	210	108	42	110	12	45	160	19×15	314	315	260	M16×36	18	415	M40×1,5	660
OMT4-IE3 160L	254	254	108	42	110	12	45	160	19×15	314	315	304	M16×36	18	415	M40×1,5	730

Dimensions of flanges

Motor type	B5						B14L					B14S				
	M	N	P	S	T	LA	M	N	P	S	T	M	N	P	S	T
OMT4-IE3 80	165	130	200	12	3,5	12	130	110	160	M8	3,5	100	80	120	M6	3,0
OMT4-IE3 90S	165	130	200	12	3,5	12	130	110	160	M8	3,5	115	95	140	M8	3,0
OMT4-IE3 90L	165	130	200	12	3,5	12	130	110	160	M8	3,5	115	95	140	M8	3,0
OMT4-IE3 100L	215	180	250	15	4	14	165	130	200	M10	3,5	130	110	160	M8	3,5
OMT4-IE3 112M	215	180	250	15	4	15	165	130	200	M10	3,5	130	110	160	M8	3,5
OMT4-IE3 132S	265	230	300	15	4	15	215	180	250	M12	4,0	165	130	200	M10	3,5
OMT4-IE3 132M	265	230	300	15	4	15	215	180	250	M12	4,0	165	130	200	M10	3,5
OMT4-IE3 160M	300	250	350	19	5	15	-	-	-	-	-	-	-	-	-	-
OMT4-IE3 160L	300	250	350	19	5	15	-	-	-	-	-	-	-	-	-	-

OMT4-IE3 series motors have a monobloc frame structure with screwed feet and with threaded sprues on the frame, which makes it possible to extend the feet and change their location to the terminal box (variant with a terminal box on the right or the left side of the motor frame). By unscrewing or tightening the feet to the body you receive an other versions of the mechanical mounting method of the motor – respectively flange mounting (B5, B14) or foot & flange mounting (B35, B34).

Note: The manufacturer reserves the right to change the operating parameters and overall dimensions as the construction is modernized.

MOTOR TYPE	Rated power	Rated current	Rated current			Efficiency IE4			Power factor	Nominal torque	Locked rotor torque	Break-down torque	Locked rotor current	Moment of inertia	Weight
	P_N	n_N	I_N			η			$\cos\phi$	M_N	M_R/M_N	M_{BR}/M_N	I_R/I_N	J	m
	kW	min ⁻¹	A 230V	A 400V	A 690V	% 4/4	% 3/4	% 1/2	- 4/4	Nm	-	-	-	kgm ²	kg

2-pole motors – nS = 3000 r/min															
OMT4-IE4 801-2	0,75	2890	2,8	1,6		83,5	83,8	82,1	0,83	2,48	2,3	2,3	7,0	0,00115	10
OMT4-IE4 802-2	1,1	2890	3,8	2,2		85,2	85,9	84,5	0,83	3,63	2,2	2,3	7,3	0,00149	11
OMT4-IE4 90S-2	1,5	2890	5,0	2,9		86,5	87,7	86,0	0,85	4,96	2,2	2,3	7,6	0,00231	17
OMT4-IE4 90L-2	2,2	2895	7,3	4,2		88,0	88,6	87,3	0,86	7,26	2,2	2,3	7,8	0,00297	21
OMT4-IE4 100L-2	3	2895		5,6	3,2	89,1	89,8	88,5	0,87	9,90	2,3	2,4	8,1	0,00475	27
OMT4-IE4 112M-2	4	2915		7,3	4,2	90,0	90,4	89,2	0,88	13,10	2,3	2,4	8,3	0,00659	35
OMT4-IE4 132S1-2	5,5	2940		9,9	5,7	90,9	91,2	90,1	0,88	17,87	2,1	2,3	8,3	0,01454	47
OMT4-IE4 132S2-2	7,5	2940		13,3	7,7	91,7	92,3	91,0	0,89	24,36	2,0	2,3	7,9	0,01707	53
OMT4-IE4 160M1-2	11	2950		19,3	11,2	92,6	92,8	91,2	0,89	35,61	2,0	2,3	8,1	0,07108	129
OMT4-IE4 160M2-2	15	2950		26,1	15,1	93,3	93,6	92,5	0,89	48,56	2,0	2,3	8,1	0,08011	140
OMT4-IE4 160L-2	18,5	2950		32,0	18,5	93,7	93,9	92,7	0,89	59,89	2,0	2,3	7,9	0,09230	165

4-pole motors – nS = 1500 r/min															
OMT4-IE4 80 2-4	0,75	1430	2,9	1,7		85,7	85,9	84,5	0,74	5,01	2,3	2,3	8,5	0,00281	13
OMT4-IE4 90S-4	1,1	1435	4,2	2,4		87,2	87,8	85,9	0,75	7,27	2,3	2,3	8,5	0,00338	16
OMT4-IE4 90L-4	1,5	1445	5,5	3,2		88,2	89,0	87,6	0,76	9,91	2,3	2,3	9,0	0,00436	20
OMT4-IE4 100L1-4	2,2	1460	7,8	4,5		89,5	90,0	88,5	0,79	14,39	2,3	2,3	9,0	0,00566	29
OMT4-IE4 100L2-4	3	1460		6,0	3,5	90,4	90,8	89,7	0,80	19,62	2,3	2,3	9,5	0,01059	33,5
OMT4-IE4 112M-4	4	1460		7,9	4,6	91,1	91,8	90,3	0,80	26,16	2,3	2,3	9,5	0,01463	41
OMT4-IE4 132S-4	5,5	1470		10,8	6,2	91,9	92,3	91,2	0,80	35,73	2,0	2,3	9,5	0,03184	57
OMT4-IE4 132M-4	7,5	1470		14,4	8,3	92,6	93,2	92,2	0,81	48,72	2,0	2,3	9,5	0,04102	67
OMT4-IE4 160M-4	11	1470		20,5	11,8	93,3	93,6	92,7	0,83	71,46	2,0	2,3	9,5	0,10966	139
OMT4-IE4 160L-4	15	1470		27,4	15,8	93,9	94,2	93,2	0,84	97,45	2,0	2,3	9,5	0,14323	163

6-pole motors – nS = 1000 r/min															
OMT4-IE4 90S-6	0,75	955	3,3	1,9		82,7	83,4	81,4	0,70	7,50	2,1	2,1	7,5	0,00440	17
OMT4-IE4 90L-6	1,1	955	4,7	2,7		84,5	85,3	83,2	0,70	11,00	2,1	2,1	7,5	0,00604	21,5
OMT4-IE4 100L-6	1,5	955	6,4	3,7		85,9	86,6	84,9	0,71	15,00	2,1	2,1	7,5	0,01230	28
OMT4-IE4 112M-6	2,2	970	9,3	5,4		87,4	87,7	86,0	0,71	21,66	2,1	2,1	7,5	0,01719	34
OMT4-IE4 132S-6	3	970		7,2	4,2	88,6	89,3	87,8	0,71	29,54	2,0	2,1	7,5	0,03613	47
OMT4-IE4 132M1-6	4	970		9,4	5,4	89,5	90,1	88,8	0,72	39,38	2,0	2,1	8,0	0,04476	59
OMT4-IE4 132M2-6	5,5	970		12,8	7,4	90,5	90,9	89,9	0,72	54,15	2,0	2,1	8,0	0,05545	65
OMT4-IE4 160M-6	7,5	980		17,1	9,9	91,3	91,7	90,5	0,73	73,09	2,0	2,1	8,0	0,09710	128
OMT4-IE4n160L-6	11	980		23,5	13,6	92,3	92,8	91,5	0,77	107,2	2,0	2,1	8,5	0,14331	168



DIMENSIONAL DRAWING

Foot mounting B3

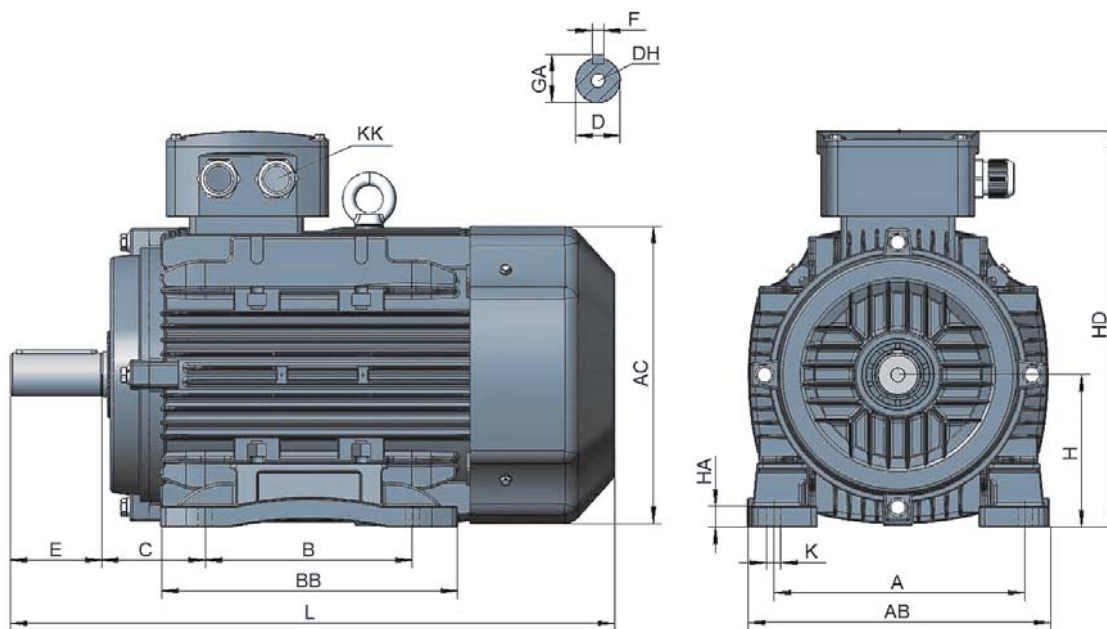

Typ silnika	A	B	C	D	E	F	GA	H	K	AB	AC	BB	DH	HA	HD	KK	L
OMT4-IE4 80	125	100	50	19	40	6	21.5	80	12×10	165	156	130	M6×16	9	218	M25×1.5	295
OMT4-IE4 90S	140	100	56	24	50	8	27	90	12×10	180	177	140	M8×19	10	241	M25×1.5	353
OMT4-IE4 90L	140	125	56	24	50	8	27	90	12×10	180	177	170	M8×19	10	241	M25×1.5	373
OMT4-IE4 100L	160	140	63	28	60	8	31	100	16×12	205	198	190	M10×22	11	280	M25×1.5	433
OMT4-IE4 112M	190	140	70	28	60	8	31	112	16×12	226	235	200	M10×22	15	293	M32×1.5	461
OMT4-IE4 132S	216	140	89	38	80	10	41	132	16×12	262	293	216	M12×28	18	344	M32×1.5	499
OMT4-IE4 132M	216	178	89	38	80	10	41	132	16×12	262	293	256	M12×28	18	344	M32×1.5	521
OMT4-IE4 160M	254	210	108	42	110	12	45	160	19×15	320	315	260	M16×36	18	415	M40×1.5	660
OMT4-IE4 160L	254	254	108	42	110	12	45	160	19×15	320	315	304	M16×36	18	415	M40×1.5	730

Foot & flange mounting B35
Flange mounting B5/V1

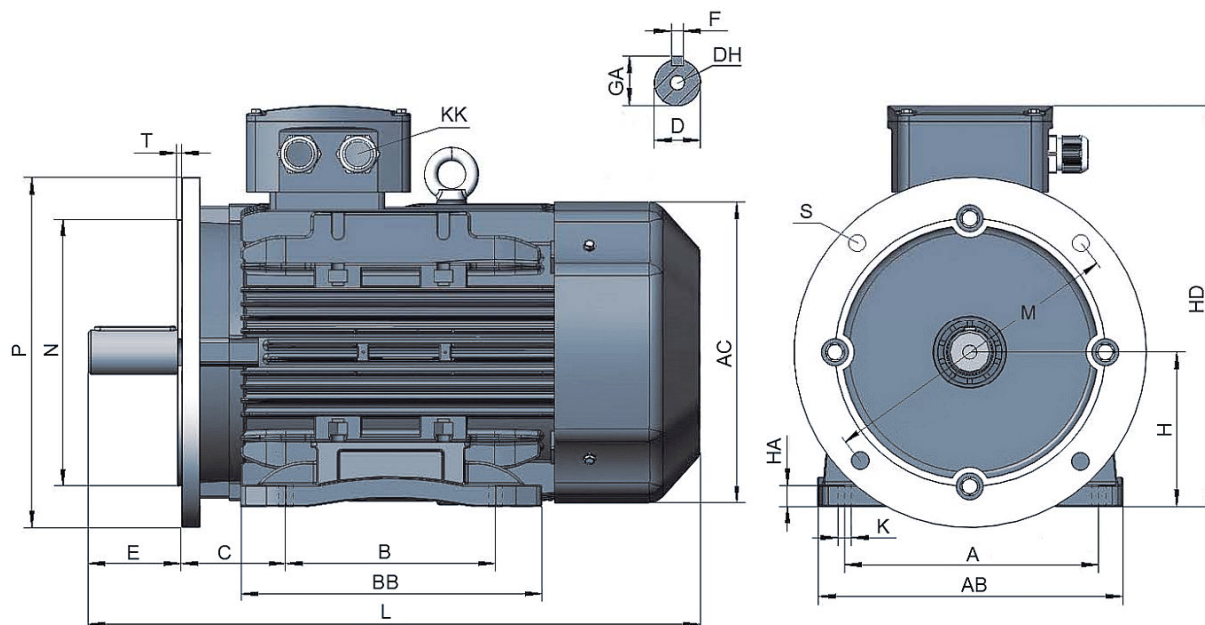

DIMENSIONAL DRAWING

Foot & flange mounting B34S, B34L
Flange mounting B14S, B14L

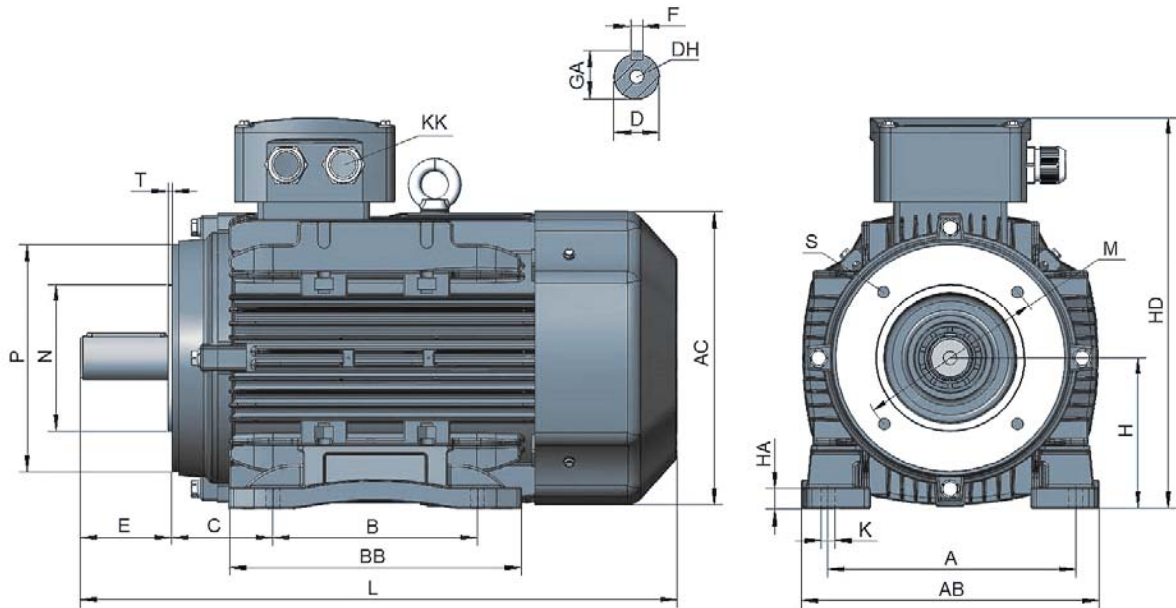

Typ silnika	A	B	C	D	E	F	GA	H	K	AB	AC	BB	DH	HA	HD	KK	L
OMT4-IE4 80	125	100	50	19	40	6	21,5	80	12×10	165	156	130	M6×16	9	218	M25×1,5	295
OMT4-IE4 90S	140	100	56	24	50	8	27	90	12×10	180	177	140	M8×19	10	241	M25×1,5	353
OMT4-IE4 90L	140	125	56	24	50	8	27	90	12×10	180	177	170	M8×19	10	241	M25×1,5	373
OMT4-IE4 100L	160	140	63	28	60	8	31	100	16×12	205	198	190	M10×22	11	280	M25×1,5	433
OMT4-IE4 112M	190	140	70	28	60	8	31	112	16×12	226	235	200	M10×22	15	293	M32×1,5	461
OMT4-IE4 132S	216	140	89	38	80	10	41	132	16×12	262	293	216	M12×28	18	344	M32×1,5	499
OMT4-IE4 132M	216	178	89	38	80	10	41	132	16×12	262	293	256	M12×28	18	344	M32×1,5	521
OMT4-IE4 160M	254	210	108	42	110	12	45	160	19×15	320	315	260	M16×36	18	415	M40×1,5	660
OMT4-IE4 160L	254	254	108	42	110	12	45	160	19×15	320	315	304	M16×36	18	415	M40×1,5	730

Typ silnika	B5						B14L					B14S				
	M	N	P	S	T	LA	M	N	P	S	T	M	N	P	S	T
OMT4-IE4 80	165	130	200	12	3,5	12	130	110	160	M8	3,5	100	80	120	M6	3,0
OMT4-IE4 90S	165	130	200	12	3,5	12	130	110	160	M8	3,5	115	95	140	M8	3,0
OMT4-IE4 90L	165	130	200	12	3,5	12	130	110	160	M8	3,5	115	95	140	M8	3,0
OMT4-IE4 100L	215	180	250	15	4	14	165	130	200	M10	3,5	130	110	160	M8	3,5
OMT4-IE4 112M	215	180	250	15	4	15	165	130	200	M10	3,5	130	110	160	M8	3,5
OMT4-IE4 132S	265	230	300	15	4	15	215	180	250	M12	4,0	165	130	200	M10	3,5
OMT4-IE4 132M	265	230	300	15	4	15	215	180	250	M12	4,0	165	130	200	M10	3,5
OMT4-IE4 160M	300	250	350	19	5	15	-	-	-	-	-	-	-	-	-	-
OMT4-IE4 160L	300	250	350	19	5	15	-	-	-	-	-	-	-	-	-	-

OMT4-IE4 series motors have a monobloc frame structure with screwed feet and with threaded sprues on the frame, which makes it possible to extend the feet and change their location to the terminal box (variant with a terminal box on the right or the left side of the motor frame). By unscrewing or tightening the feet to the body you receive an other versions of the mechanical mounting method of the motor – respectively flange mounting (B5, B14) or foot & flange mounting (B35, B34).

Note: The manufacturer reserves the right to change the operating parameters and overall dimensions as the construction is modernized.

MOTOR TYPE	Rated power	Rated speed	Rated current			Efficiency IE1			Power factor	Nominal torque	Locked torque/ rated torque	Max. torque/ rated torque	Locked current/ rated current	Moment of inertia	Weight
	P_N	n_N	I_N			η			$\cos(\varphi)$	M_N	M_L/M_N	M_{max}/M_N	I_L/I_N	J	m
	kW	min ⁻¹	A 230V	A 400V	A 690V	% 4/4	% 3/4	% 1/2	-	Nm	-	-	-	kgm ²	kg

2-pole motors – n _s = 3000 r/min															
OMT3 80 1-2	0,75	2845	3,1	1,8		72,1	71,2	62,0	0,83	2,52	2,3	2,2	6,1	0,00080	14
OMT3 80 2-2	1,1	2845	4,4	2,5		75,0	74,1	64,3	0,84	3,69	2,3	2,2	6,9	0,00087	15
OMT3 80C-2 *	1,5	2850	5,8	3,3		77,2	77,0	74,2	0,84	5,03	2,2	2,3	7,0	0,00097	16
OMT3 90S-2	1,5	2850	5,8	3,3		77,2	76,8	71,1	0,84	5,03	2,3	2,2	7,0	0,0013	17
OMT3 90L-2	2,2	2855	8,2	4,7		79,7	80,0	78,3	0,85	7,36	2,3	2,2	7,0	0,0014	23
OMT3 90C-2 *	3	2860		6,1	3,5	81,5	81,5	79,4	0,87	10,0	2,2	2,3	7,5	0,0015	21
OMT3 100L1-2	3	2860		6,1	3,5	81,5	81,4	79,2	0,87	10,0	2,3	2,4	7,5	0,0030	30
OMT3 100C-2 *	4	2880		7,9	4,6	83,1	83,1	81,1	0,88	13,3	2,2	2,3	7,5	0,0031	34
OMT3 112M-2	4	2880		7,9	4,6	83,1	83,4	80,6	0,88	13,3	2,3	2,2	7,4	0,0056	41
OMT3 112C-2 *	5,5	2900		10,7	6,2	84,7	83,5	80,5	0,88	18,1	2,2	2,3	7,5	0,0059	46
OMT3 132S1-2	5,5	2900		10,7	6,2	84,7	84,3	82,0	0,88	18,1	2,3	2,5	7,5	0,0126	58
OMT3 132S2-2	7,5	2900		14,3	8,3	86,0	86,3	85,5	0,88	24,7	2,2	2,4	7,4	0,0136	61
OMT3 132C-2 *	9,2	2900		17,5	10,2	86,0	85,9	84,3	0,88	30,3	2,2	2,3	7,5	0,0140	70
OMT3 132CB-2 *	11	2930		20,4	11,8	87,6	86,6	84,5	0,89	35,9	2,2	2,3	7,5	0,0150	74
OMT3 160M1-2	11	2930		20,4	11,8	87,6	87,7	85,5	0,89	35,9	2,2	2,4	7,5	0,0438	107
OMT3 160M2-2	15	2930		27,4	15,9	88,7	87,9	85,5	0,89	48,9	2,3	2,4	7,5	0,0544	114
OMT3 160L-2	18,5	2930		33,2	19,3	89,3	89,4	88,2	0,90	60,3	2,3	2,2	7,5	0,0647	133
OMT3 160LX-2 *	22	2940		39,2	22,7	89,9	89,3	87,1	0,90	71,5	2,0	2,3	7,5	0,0670	138
OMT3 180M-2	22	2940		39,2	22,7	89,9	89,4	87,5	0,90	71,5	2,0	2,3	7,5	0,0794	165
OMT3 180L-2 *	30	2950		53,0	30,6	90,7	89,6	87,0	0,90	97,1	2,0	2,3	7,5	0,0830	206
OMT3 200L1-2	30	2950		53,0	30,6	90,7	89,9	87,8	0,90	97,1	2,0	2,3	7,5	0,1515	218
OMT3 200L2-2	37	2950		65,1	37,6	91,2	90,8	89,9	0,90	120	2,0	2,3	7,5	0,1533	230
OMT3 200LX-2 *	45	2960		78,7	45,4	91,7	90,1	87,6	0,90	145	2,0	2,3	7,5	0,1540	262
OMT3 225M1-2	45	2960		78,7	45,4	91,7	91,2	89,4	0,90	145	2,1	2,4	7,5	0,2530	290
OMT3 225M2-2 *	55	2970		95,8	55,3	92,1	91,0	88,3	0,90	177	2,0	2,4	7,5	0,2590	324
OMT3 250M1-2	55	2970		95,8	55,3	92,1	91,5	89,9	0,90	177	2,0	2,4	7,5	0,3414	359
OMT3 250M2-2 *	75	2975		128	74,1	92,7	92,2	90,6	0,91	241	2,0	2,3	7,0	0,3460	440
OMT3 280S-2	75	2975		128	74,1	92,7	92,5	91,2	0,91	241	2,0	2,3	6,8	0,5950	475
OMT3 280M-2	90	2975		154	88,6	93,0	92,8	92,0	0,91	289	2,0	2,4	6,9	0,6762	510
OMT3 280MX-2 *	110	2975		187	108	93,3	92,8	91,3	0,91	353	1,8	2,2	7,0	0,729	569
OMT3 315S-2	110	2975		187	108	93,3	92,9	92,1	0,91	353	1,8	2,3	7,0	1,394	875
OMT3 315M-2	132	2975		224	129	93,5	92,8	91,2	0,91	424	1,8	2,2	6,8	1,542	963
OMT3 315L1-2	160	2975		268	155	93,8	93,4	92,2	0,92	514	1,8	2,3	7,1	1,709	1010
OMT3 315L2-2	200	2975		334	193	94,0	93,8	92,8	0,92	642	1,8	2,3	7,0	1,922	1138
OMT3 355M1-2	220	2975		367	212	94,0	93,0	91,5	0,92	706	1,6	2,2	7,1	2,650	1700
OMT3 355M2-2	250	2980		417	241	94,0	93,2	91,4	0,92	801	1,6	2,2	7,0	3,216	1780
OMT3 355L1-2	280	2980		467	270	94,0	93,0	91,5	0,92	897	1,6	2,2	7,1	3,240	1840
OMT3 355L2-2	315	2980		526	304	94,0	93,7	92,7	0,92	1009	1,6	2,3	7,1	3,711	1960
OMT3 355L3-2	355	2980		593	342	94,0	94,0	92,8	0,92	1138	1,6	2,2	7,1	3,780	2170

* - progressive motors



MOTOR TYPE	Rated power	Rated speed	Rated current			Efficiency IE1			Power factor	Nominal torque	Locked torque/ rated torque	Max. torque/ rated torque	Locked current/ rated current	Moment of inertia	Weight
	P_N	n_N	I_N			η			$\cos\varphi$	M_N	M_R/M_N	M_{MX}/M_N	I_R/I_N	J	m
	kW	min ⁻¹	A 230V	A 400V	A 690V	% 4/4	% 3/4	% 1/2	-	Nm	-	-	-	kgm ²	kg

4-pole motors – $n_s = 1500$ r/min															
OMT3 80 1-4	0.55	1380	2.6	1.5		73.9	72.2	69.7	0.76	3.81	2.3	2.4	5.2	0.0018	15
OMT3 80 2-4	0.75	1380	3.4	2.0		72.1	70.8	65.6	0.76	5.19	2.3	2.3	6.0	0.0021	15.5
OMT3 80C-4 *	1.1	1390	4.8	2.7		75.0	78.4	75.6	0.77	7.56	2.3	2.3	6.0	0.0024	14
OMT3 90S-4	1.1	1390	4.8	2.7		75.0	75.3	72.8	0.77	7.56	2.3	2.3	5.8	0.0025	19
OMT3 90L-4	1.5	1400	6.2	3.6		77.2	77.1	76.0	0.78	10.2	2.3	2.4	6.0	0.0028	23
OMT3 90C-4 *	2.2	1420	8.6	4.9		79.7	80.1	78.2	0.81	14.8	2.3	2.3	7.0	0.0029	26
OMT3 100L1-4	2.2	1420	8.6	4.9		79.7	78.2	75.3	0.81	14.8	2.3	2.4	6.9	0.0060	29
OMT3 100L2-4	3	1420		6.5	3.7	81.5	80.8	77.4	0.82	20.2	2.3	2.5	7.0	0.0067	31
OMT3 100C-4 *	4	1435		8.5	4.9	83.1	82.9	80.8	0.82	26.6	2.3	2.3	7.0	0.0072	35
OMT3 112M-4	4	1435		8.5	4.9	83.1	83.3	82.2	0.82	26.6	2.3	2.6	6.8	0.0096	42
OMT3 112C-4 *	5.5	1440		11.3	6.5	84.7	84.8	83.6	0.83	36.5	2.3	2.3	7.0	0.0103	47
OMT3 132S-4	5.5	1440		11.3	6.5	84.7	84.5	82.8	0.83	36.5	2.3	2.7	7.0	0.0244	63.5
OMT3 132M-4	7.5	1450		15.0	8.7	86.0	86.2	85.3	0.84	49.4	2.3	2.6	7.0	0.0272	72
OMT3 132C-4 *	9.2	1450		18.4	10.7	86.0	86.3	85.3	0.84	60.6	2.2	2.3	7.0	0.0320	79
OMT3 132CB-4 *	11	1460		21.6	12.5	87.6	87.6	86.2	0.84	72.0	2.2	2.4	7.0	0.0410	83
OMT3 160M-4	11	1460		21.6	12.5	87.6	87.8	86.9	0.84	72.0	2.2	2.4	7.0	0.0747	110
OMT3 160L-4	15	1460		28.7	16.6	88.7	88.9	88.0	0.85	98.1	2.2	2.5	7.4	0.0918	129
OMT3 160LX-4 *	18.5	1470		34.8	20.2	89.3	89.2	87.8	0.86	120	2.2	2.3	7.5	0.1030	147
OMT3 180M-4	18.5	1470		34.8	20.2	89.3	89.4	88.3	0.86	120	2.2	2.5	7.3	0.1484	160
OMT3 180L-4	22	1470		41.1	23.7	89.9	90.1	89.0	0.86	143	2.2	2.5	7.2	0.1642	173
OMT3 180LX-4 *	30	1470		55.5	32.2	90.7	90.5	89.7	0.86	195	2.2	2.3	7.2	0.1770	200
OMT3 200L-4	30	1470		55.5	32.2	90.7	90.9	89.1	0.86	195	2.2	2.5	7.2	0.2703	224
OMT3 200LX-4 *	37	1475		67.3	39.0	91.2	91.1	89.9	0.87	240	2.2	2.3	7.2	0.2940	262
OMT3 225S-4	37	1475		67.3	39.0	91.2	91.1	89.8	0.87	240	2.2	2.5	7.0	0.4643	288
OMT3 225M1-4	45	1475		81.4	47.0	91.7	91.7	90.6	0.87	291	2.2	2.6	7.1	0.5160	313
OMT3 225M2-4 *	55	1480		99.1	57.4	92.1	92.3	91.7	0.87	355	2.2	2.3	7.2	0.5250	340
OMT3 250M1-4	55	1480		99.1	57.4	92.1	92.0	90.9	0.87	355	2.2	2.6	7.2	0.6821	376
OMT3 250M2-4 *	75	1480		133	76.9	92.7	92.2	90.7	0.88	484	2.2	2.3	6.8	0.740	447
OMT3 280M-4	90	1480		159	92.0	93.0	92.6	91.4	0.88	581	2.1	2.5	6.8	1.537	581
OMT3 280MX-4 *	110	1480		193	112	93.3	92.4	90.3	0.88	710	2.1	2.2	6.9	1.770	648
OMT3 315S-4	110	1480		193	112	93.3	93.1	91.9	0.88	710	2.1	2.3	6.8	2.950	846
OMT3 315M-4	132	1480		232	134	93.5	93.4	92.3	0.88	852	2.1	2.3	6.7	3.445	940
OMT3 315L1-4	160	1480		277	160	93.8	93.5	92.4	0.89	1032	2.1	2.3	6.7	3.641	1044
OMT3 315L2-4	200	1480		345	199	94.0	93.9	93.1	0.89	1291	2.1	2.3	6.8	4.425	1162
OMT3 355M1-4	220	1490		375	218	94.0	93.4	92.4	0.90	1410	2.1	2.2	6.9	5.120	1600
OMT3 355M2-4	250	1490		427	246	94.0	94.2	93.3	0.90	1602	2.1	2.2	6.8	7.009	1700
OMT3 355L1-4	280	1490		478	277	94.0	93.4	92.4	0.90	1795	2.1	2.2	6.9	7.040	1780
OMT3 355L2-4	315	1490		537	310	94.0	93.8	92.7	0.90	2019	2.1	2.3	6.9	8.615	1900
OMT3 355L3-4	355	1490		606	351	94.0	94.0	92.8	0.90	2275	2.1	2.2	6.9	8.860	2040

6-pole motors – $n_s = 1000$ r/min															
OMT3 80 1-6	0.37	880	2.14	1.23		61.8	59.3	54.8	0.70	4.02	1.9	2.1	4.7	0.0016	15
OMT3 80 2-6	0.55	880	2.95	1.70		63.0	62.0	60.1	0.72	5.97	1.9	2.2	4.7	0.0019	16
OMT3 80C-6 *	0.75	900	3.8	2.2		70.0	69.2	63.1	0.72	7.96	2.0	2.0	5.2	0.0024	19
OMT3 90S-6	0.75	905	3.8	2.2		70.0	69.2	63.1	0.72	7.91	2.1	2.0	5.3	0.0029	20
OMT3 90L-6	1.1	905	5.2	3.0		72.9	72.7	69.7	0.73	11.6	2.1	2.1	5.5	0.0035	23
OMT3 90C-6 *	1.5	920	6.7	3.8		75.2	75.2	72.4	0.75	15.6	2.0	2.1	5.5	0.0038	24
OMT3 100L1-6	1.5	920	6.7	3.8		75.2	75.4	71.0	0.75	15.6	2.1	2.1	5.5	0.0069	29
OMT3 100C-6 *	2.2	935	9.4	5.4		77.7	77.7	74.6	0.76	22.5	2.0	2.1	6.5	0.0075	35
OMT3 112M-6	2.2	935	9.4	5.4		77.7	77.4	75.9	0.76	22.5	2.0	2.2	6.5	0.0140	41
OMT3 112C-6 *	3	960		7.10	4.10	79.7	79.8	77.3	0.76	29.8	2.1	2.1	6.5	0.0152	45
OMT3 132S-6	3	960		7.15	4.14	79.7	79.0	76.3	0.76	29.8	2.1	2.1	6.5	0.0286	59
OMT3 132M1-6	4	960		9.33	5.41	81.4	81.0	78.0	0.76	39.8	2.1	2.1	6.5	0.0357	66
OMT3 132M2-6	5.5	960		12.4	7.18	83.1	82.6	82.4	0.77	54.7	2.1	2.1	6.5	0.0449	76.5
OMT3 132C-6 *	7.5	970		16.6	9.60	84.7	84.7	83.2	0.77	73.8	2.0	2.1	6.5	0.0509	86

MOTOR TYPE	Rated power	Rated speed	Rated current			Efficiency IEI			Power factor	Nominal torque	Locked torque/ rated torque	Max. torque/ rated torque	Locked current/ rated current	Moment bezw adnoi	Weight
	P_N	n_n	I_N			η			$\cos\phi$	M_N	M_L/M_N	M_{max}/M_N	I_L/I_N	J	m
	kW	min ⁻¹	A 230V	A 400V	A 690V	% 4/4	% 3/4	% 1/2	-	Nm	-	-	-	kgm ²	kg

6-pole motors – $n_s = 1000$ r/min - continued															
OMT3 160M-6	7,5	970		16,6	9,60	84,7	84,8	83,7	0,77	73,8	2,0	2,2	6,5	0,0810	106
OMT3 160L-6	11	970		23,6	13,7	86,4	86,6	85,1	0,78	108	2,0	2,1	6,5	0,1160	122
OMT3 160LX-6 *	15	970		30,5	17,7	87,7	87,7	86,4	0,81	148	2,0	2,0	6,8	0,1250	151
OMT3 180L-6	15	970		30,5	17,7	87,7	87,9	86,0	0,81	148	2,0	2,0	6,8	0,2065	167
OMT3 200L1-6	18,5	980		37,2	21,5	88,6	88,7	87,3	0,81	180	2,1	2,1	6,8	0,2990	236
OMT3 200L2-6	22	980		42,9	24,8	89,2	89,4	88,3	0,83	214	2,0	2,1	6,8	0,3386	247
OMT3 225M-6	30	980		57,2	33,0	90,2	90,2	88,9	0,84	292	2,0	2,1	6,7	0,5702	287
OMT3 250M-6	37	980		68,4	39,5	90,8	90,5	89,6	0,86	361	2,1	2,1	6,9	0,7989	355
OMT3 280S-6	45	980		82,6	47,7	91,4	91,5	90,5	0,86	439	2,1	2,0	6,7	1,459	444
OMT3 280M-6	55	980		100	58,0	91,9	91,7	91,0	0,86	536	2,1	1,9	6,7	1,715	498
OMT3 315S-6	75	985		136	78,5	92,6	92,1	90,4	0,86	727	2,0	2,1	6,5	3,162	859
OMT3 315M-6	90	985		163	93,9	92,9	92,6	91,4	0,86	873	2,0	2,1	6,6	3,686	950
OMT3 315L1-6	110	985		198	114	93,3	93,1	92,1	0,86	1066	2,0	2,0	6,5	4,481	1031
OMT3 315L2-6	132	985		234	135	93,5	93,5	92,3	0,87	1280	2,0	2,0	6,4	5,105	1107
OMT3 315L3-6	160	985		280	162	93,8	93,1	91,9	0,88	1543	1,9	2,0	6,7	6,670	1185
OMT3 355M1-6	160	990		280	162	93,8	93,7	92,6	0,88	1543	1,9	2,1	6,7	9,177	1550
OMT3 355M2-6	185	990		324	188	93,8	93,1	91,9	0,88	1785	1,9	2,0	6,7	10,36	1580
OMT3 355M3-6	200	990		349	201	94,0	93,8	92,9	0,88	1929	1,9	2,1	6,8	10,69	1600
OMT3 355L1-6	220	990		384	223	94,0	93,6	92,8	0,88	2122	1,9	2,0	6,7	11,34	1700
OMT3 355L2-6	250	990		436	252	94,0	94,1	93,2	0,88	2412	1,9	2,1	6,6	11,68	1910
OMT3 355L3-6	280	990		489	283	94,0	94,0	93,0	0,88	2412	1,9	2,0	6,7	13,52	2100

8-pole motors – $n_s = 750$ r/min															
OMT3 80 1-8	0,18	645	1,45	0,84		51,0	49,0	41,2	0,61	2,67	1,9	1,8	3,3	0,0025	15
OMT3 80 2-8	0,25	645	1,91	1,10		54,0	51,9	42,5	0,61	3,70	1,9	1,8	3,3	0,0030	16
OMT3 90S-8	0,37	675	2,46	1,41		62,0	59,0	51,1	0,61	5,23	1,9	1,9	4,0	0,0051	20
OMT3 90L-8	0,55	680	3,57	2,06		63,0	60,1	53,2	0,61	7,72	2,0	1,9	4,0	0,0065	23
OMT3 90C-8 *	0,75	680	4,20	2,42		71,0	67,0	61,4	0,63	10,53	1,7	2,0	4,5	0,0078	25
OMT3 100L1-8	0,75	680	4,00	2,30		71,0	68,9	62,4	0,67	10,53	1,8	2,0	4,0	0,0095	29
OMT3 100L2-8	1,1	680	5,56	3,20		73,0	72,5	67,5	0,69	15,45	1,8	2,0	5,0	0,0109	31
OMT3 100C-8 *	1,5	690	7,30	4,22		75,0	73,0	67,1	0,70	20,76	1,8	2,0	5,0	0,0133	35
OMT3 112M-8	1,5	690	7,30	4,22		75,0	73,9	68,3	0,70	20,76	1,8	2,0	5,0	0,0245	41
OMT3 112C-8 *	2,2	710	9,80	5,70		79,0	79,2	74,8	0,71	29,59	1,8	2,0	6,0	0,0265	47
OMT3 132S-8	2,2	710	9,80	5,70		79,0	77,9	74,3	0,71	29,59	1,9	2,0	6,0	0,0314	61
OMT3 132M-8	3	710		7,40	4,30	79,0	77,2	74,1	0,73	40,35	2,0	2,0	6,0	0,0395	75
OMT3 132C-8 *	4	720		9,80	5,70	81,0	80,5	79,2	0,73	53,06	1,9	2,0	6,0	0,0427	77
OMT3 160M1-8	4	720		9,80	5,70	81,0	79,1	78,9	0,73	53,06	2,0	2,1	6,0	0,0753	92,5
OMT3 160M2-8	5,5	720		12,9	7,46	83,0	82,2	80,2	0,74	72,95	2,0	2,1	6,5	0,0931	107
OMT3 160L-8	7,5	725		16,9	9,77	85,5	83,3	82,1	0,75	98,79	2,0	2,0	6,5	0,1247	128
OMT3 180L-8	11	730		24,2	14,0	87,5	85,0	83,8	0,75	144	2,0	2,2	6,3	0,2010	169
OMT3 200L-8	15	730		32,4	18,7	88,0	87,8	86,2	0,76	196	2,0	2,3	6,4	0,3356	236
OMT3 225S-8	18,5	730		39,0	22,5	90,0	89,5	88,2	0,76	242	1,9	2,2	6,8	0,4861	274
OMT3 225M-8	22	730		45,0	26,0	90,5	88,9	87,8	0,78	288	1,9	2,2	6,8	0,5415	290
OMT3 250M-8	30	730		60,2	34,8	91,0	89,0	87,7	0,79	392	1,9	2,2	6,3	0,8257	370
OMT3 280S-8	37	730		73,9	42,7	91,5	91,3	89,8	0,79	484	1,9	2,1	6,2	1,634	488
OMT3 280M-8	45	740		89,4	51,6	92,0	91,8	90,7	0,79	581	1,9	2,1	6,4	1,911	563
OMT3 315S-8	55	740		106	61,0	92,8	92,2	90,5	0,81	710	1,8	2,0	6,2	4,742	852
OMT3 315M-8	75	740		144	83,0	93,0	92,1	90,5	0,81	968	1,8	2,0	6,6	5,524	933
OMT3 315L1-8	90	740		169	97,5	93,8	92,8	91,3	0,82	1161	1,8	2,1	6,7	7,821	1027
OMT3 315L2-8	110	740		206	119	94,0	92,9	91,6	0,82	1420	1,9	2,1	6,4	10,20	1117
OMT3 355M1-8	132	745		248	143	93,7	93,3	92,1	0,82	1692	1,8	2,0	6,7	11,77	1800
OMT3 355M2-8	160	745		299	173	94,2	93,5	92,1	0,82	2051	1,6	2,0	6,3	13,13	1890
OMT3 355L1-8	185	745		346	200	94,2	94,2	92,9	0,82	2371	1,8	2,0	6,4	14,23	2205
OMT3 355L2-8	200	745		368	213	94,5	93,6	92,4	0,83	2564	1,8	2,0	6,6	16,36	2250
OMT3 355L3-8	220	745		405	235	94,5	94,0	92,0	0,83	2820	1,8	2,0	6,4	18,65	2320

* - progressive motors

DIMENSIONAL DRAWING

Foot mounting B3

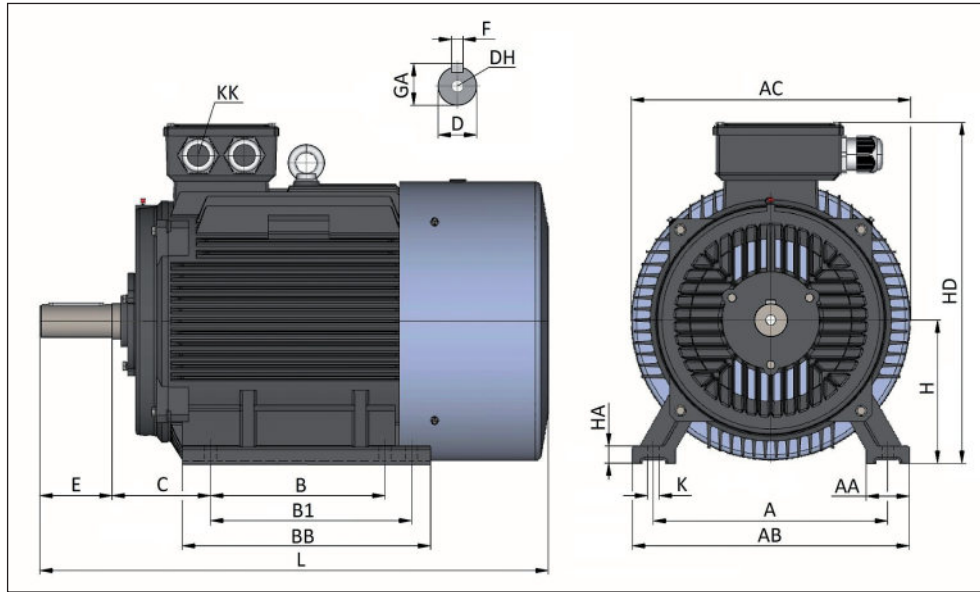

Foot & flange mounting B35

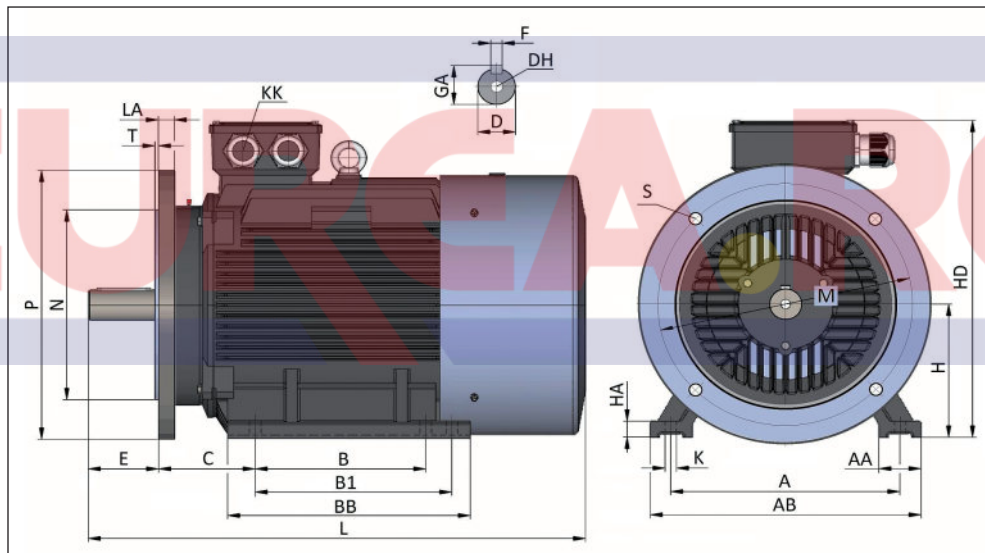

Flange mounting B5/V1

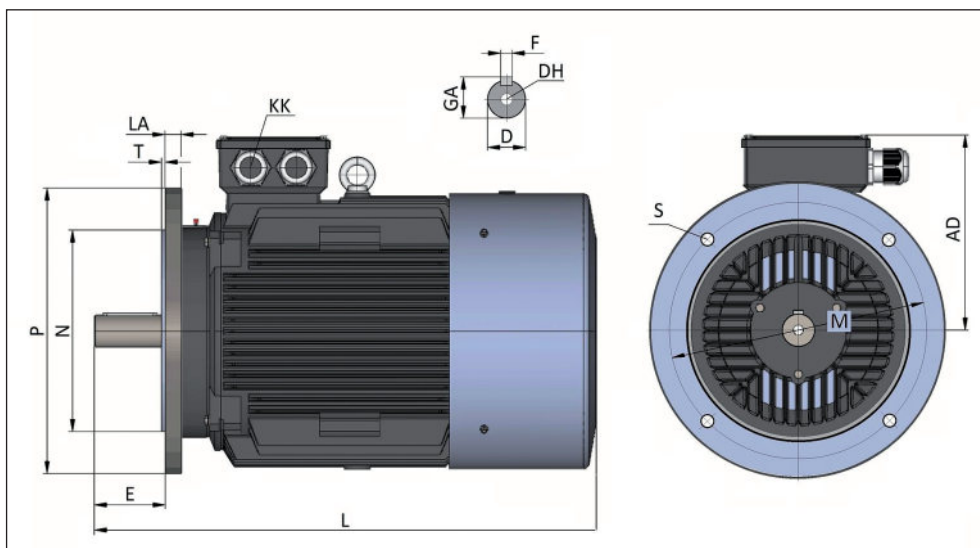

ASSEMBLY AND OVERALL DIMENSIONS

Frame size	2p	A	B	B1	C	D	E	F	GA	H	K	AA	AB	AC	AD	BB	DH	HA	HD	L	KK
OMT3-80	2-8	125	100	-	50	19	40	6	21.5	80	10	35	160	155	134	130	M6	12	214	289	M20x1.5
OMT3-90S	2-8	140	100	-	56	24	50	8	27	90	10	36	176	175	165	140	M8	12	255	324	M25x1.5
OMT3-90L.C	2-8	140	125	-	56	24	50	8	27	90	10	36	176	175	165	165	M8	12	255	346	M25x1.5
OMT3-100L.C	2-8	160	140	-	63	28	60	8	31	100	12	40	200	195	170	175	M10	14	264	375	M25x1.5
OMT3-112M.C	2-8	190	140	-	70	28	60	8	31	112	12	45	230	220	201	180	M10	15	313	403	M32x1.5
OMT3-132S	2-8	216	140	-	89	38	80	10	41	132	12	56	264	258	206	225	M12	18	338	504	M32x1.5
OMT3-132M.C	2-8	216	178	-	89	38	80	10	41	132	12	56	264	258	206	225	M12	18	338	504	M32x1.5
OMT3-160M	2-8	254	210	-	108	42	110	12	45	160	15	65	314	315	256	260	M16	20	416	613	M40x1.5
OMT3-160L	2-8	254	254	-	108	42	110	12	45	160	15	65	314	315	256	305	M16	20	416	658	M40x1.5
OMT3-180M	2-8	279	241	-	121	48	110	14	51.5	180	15	70	349	355	271	311	M16	22	451	698	M40x1.5
OMT3-180L	2-8	279	279	-	121	48	110	14	51.5	180	15	70	349	355	271	349	M16	22	451	734	M40x1.5
OMT3-200L	2-8	318	305	-	133	55	110	16	59	200	19	70	388	397	305	370	M20	25	505	776	M50x1.5
OMT3-225S	4-8	356	286	-	149	60	140	18	64	225	19	75	431	446	325	370	M20	28	550	810	M50x1.5
OMT3-225M	2	356	311	-	149	55	110	16	59	225	19	75	431	446	325	395	M20	28	550	809	M50x1.5
	4-8	356	311	-	149	60	140	18	64	225	19	75	431	446	325	395	M20	28	550	839	M50x1.5
OMT3-250M	2	406	349	-	168	60	140	18	64	250	24	80	484	485	365	445	M20	30	615	925	M63x1.5
	4-8	406	349	-	168	65	140	18	69	250	24	80	484	485	365	445	M20	30	615	925	M63x1.5
OMT3-280S	2	457	368	-	190	65	140	18	69	280	24	85	542	546	390	485	M20	35	670	998	M63x1.5
	4-8	457	368	-	190	75	140	20	79.5	280	24	85	542	546	390	485	M20	35	670	998	M63x1.5
OMT3-280M	2	457	419	-	190	65	140	18	69	280	24	85	542	546	390	540	M20	35	670	1046	M63x1.5
	4-8	457	419	-	190	75	140	20	79.5	280	24	85	542	546	390	540	M20	35	670	1046	M63x1.5
OMT3-315S	2	508	406	-	216	65	140	18	69	315	28	120	628	620	540	570	M20	45	855	1190	M63x1.5
	4-8	508	406	-	216	80	170	22	85	315	28	120	628	620	540	570	M20	45	855	1220	M63x1.5
OMT3-315M.L	2	508	457	508	216	65	140	18	69	315	28	120	628	620	540	680	M20	45	855	1295	M63x1.5
	4-8	508	457	508	216	80	170	22	85	315	28	120	628	620	540	680	M20	45	855	1325	M63x1.5
OMT3-355M	2	610		560	254	75	140	20	79.5	355	28	116	726	700	647	750	M20	52	1002	1484	M63x1.5
	4-8	610		560	254	95	170	25	100	355	28	116	726	700	647	750	M20	52	1002	1514	M63x1.5
OMT3-355L	2	610		630	254	75	140	20	79.5	355	28	116	726	700	647	750	M20	52	1002	1484	M63x1.5
	4-8	610		630	254	95	170	25	100	355	28	116	726	700	647	750	M20	52	1002	1514	M63x1.5

Dimensions of flanges

Frame size	B5						B14L					B14S				
	M	N	P	S	T	LA	M	N	P	S	T	M	N	P	S	T
OMT3-80	165	130	200	4x Ø12	3.5	12	130	110	160	4x M8	3.5	100	80	120	4x M6	3.0
OMT3-90	165	130	200	4x Ø12	3.5	12	130	110	160	4x M8	3.5	115	95	140	4x M8	3.0
OMT3-100	215	180	250	4x Ø15	4	13	165	130	200	4x M10	3.5	130	110	160	4x M8	3.5
OMT3-112	215	180	250	4x Ø15	4	14	165	130	200	4x M10	3.5	130	110	160	4x M8	3.5
OMT3-132	265	230	300	4x Ø15	4	14	215	180	250	4x M12	4.0	165	130	200	4x M10	3.5
OMT3-160	300	250	350	4x Ø19	5	15										
OMT3-180	300	250	350	4x Ø19	5	15										
OMT3-200	350	300	400	4x Ø19	5	17										
OMT3-225	400	350	450	8x Ø19	5	20										
OMT3-250	500	450	550	8x Ø19	5	22										
OMT3-280	500	450	550	8x Ø19	6	22										
OMT3-315	600	550	660	8x Ø24	6	22										
OMT3-355	740	680	800	8x Ø24	6	25										

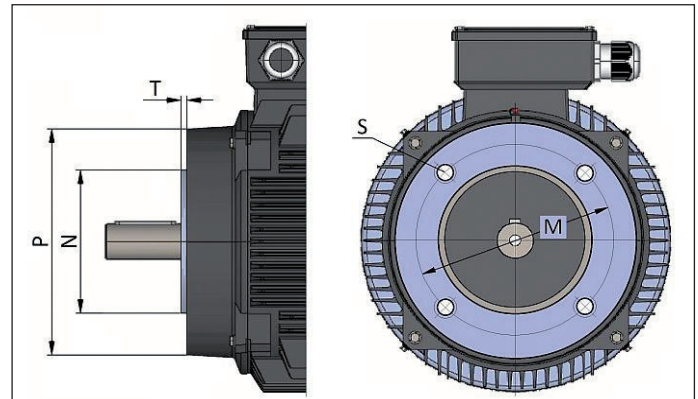

Comments:

- 1) Flange motors mounted in position B5 are available for frame sizes 80 to 280.
- 2) Flange motors mounted in position V1 can be supplied with an additional small protective roof.
- 3) Flange motors B14S and B14L are available only for frame sizes 80 to 132.

Note: The manufacturer reserves the right to change the operating parameters and overall dimensions as the construction is modernized.

MOTOR TYPE	Rated power	Rated speed	Rated current			Efficiency IE3			Power factor	Nominal torque	Locked torque/ rated torque	Max. torque/ rated torque	Locked current/ rated current	Weight
	P_N	n_N	I_N			η			$\cos(\varphi)$	M_N	M_R/M_N	M_{max}/M_N	I_R/I_N	m
	kW	min ⁻¹	A 230V	A 400V	A 690V	% 4/4	% 3/4	% 1/2	-	Nm	-	-	-	kg

2-pole motors – $n_s = 3000$ r/min														
OMT3-IE3 80 1-2	0,75	2890	2,83	1,64		80,7	81,0	79,3	0,82	2,48	2,3	2,3	7,0	17
OMT3-IE3 80 2-2	1,1	2890	4,01	2,31		82,7	83,4	82,0	0,83	3,63	2,2	2,3	7,3	19
OMT3-IE3 90S-2	1,5	2890	5,30	3,06		84,2	83,6	82,0	0,84	4,96	2,2	2,3	7,6	23
OMT3-IE3 90L1-2	2,2	2890	7,53	4,35		85,9	85,4	84,1	0,85	7,27	2,2	2,3	7,6	27
OMT3-IE3 100L1-2	3	2895		5,71	3,3	87,1	86,8	85,5	0,87	9,90	2,2	2,3	7,8	36
OMT3-IE3 112M-2	4	2910		7,45	4,3	88,1	87,3	86,1	0,88	13,1	2,2	2,3	8,3	46
OMT3-IE3 132S1-2	5,5	2940		10,1	5,9	89,2	88,6	87,5	0,88	17,9	2,0	2,3	8,3	68
OMT3-IE3 132S2-2	7,5	2940		13,5	7,9	90,1	89,7	88,4	0,89	24,4	2,0	2,3	7,9	79
OMT3-IE3 160M1-2	11	2950		19,6	11,3	91,2	90,7	89,1	0,89	35,6	2,0	2,3	8,1	116
OMT3-IE3 160M2-2	15	2950		26,5	15,3	91,9	91,6	90,5	0,89	48,6	2,0	2,3	8,1	129
OMT3-IE3 160L-2	18,5	2950		32,5	18,8	92,4	92,5	91,3	0,89	59,9	2,0	2,3	8,2	168
OMT3-IE3 180M-2	22	2960		38,5	22,3	92,7	92,2	90,9	0,89	71,0	2,0	2,5	8,2	184
OMT3-IE3 200L1-2	30	2970		52,1	30,2	93,3	93,2	91,8	0,89	96,5	2,0	2,3	7,6	249
OMT3-IE3 200L2-2	37	2970		64,0	37,1	93,7	93,5	92,2	0,89	119	2,0	2,3	7,6	263
OMT3-IE3 225M1-2	45	2970		76,8	44,5	94,0	93,7	92,4	0,90	145	2,0	2,3	7,7	342
OMT3-IE3 250M1-2	55	2980		93,5	54,2	94,3	94,1	92,5	0,90	176	2,0	2,3	7,7	370
OMT3-IE3 280S-2	75	2980		127	73,6	94,7	94,2	93,6	0,90	240	1,8	2,3	7,1	517
OMT3-IE3 280M-2	90	2980		152	88,1	95,0	95,0	94,1	0,90	288	1,8	2,3	7,1	562
OMT3-IE3 315S-2	110	2980		185	107	95,2	95,1	94,3	0,90	353	1,8	2,3	7,1	843
OMT3-IE3 315M-2	132	2980		222	129	95,4	95,2	94,3	0,90	423	1,8	2,3	7,0	923
OMT3-IE3 315L1-2	160	2980		265	154	95,6	95,3	94,5	0,91	513	1,8	2,3	7,2	997
OMT3-IE3 315L2-2	200	2980		331	192	95,8	95,7	94,8	0,91	641	1,8	2,2	7,2	1087
OMT3-IE3 355M-2	250	2980		414	240	95,8	95,7	94,8	0,91	801	1,6	2,2	7,2	1606
OMT3-IE3 355L2-2	315	2980		522	302	95,8	95,7	94,8	0,91	1009	1,6	2,2	7,2	1802

4-pole motors – $n_s = 1500$ r/min														
OMT3-IE3 80 2-4	0,75	1430	3,03	1,75		82,5	82,7	81,3	0,75	5,01	2,3	2,3	6,6	18
OMT3-IE3 90S-4	1,1	1440	4,36	2,48		84,1	84,7	82,8	0,75	7,30	2,3	2,3	6,8	26
OMT3-IE3 90L1-4	1,5	1440	5,71	3,3		85,3	85,1	84,7	0,77	9,95	2,3	2,3	7,0	28
OMT3-IE3 100L1-4	2,2	1455	7,83	4,52		86,7	87,2	85,7	0,81	14,4	2,3	2,3	7,6	38
OMT3-IE3 100L2-4	3	1455		6,02	3,48	87,7	88,1	87,0	0,82	19,7	2,3	2,3	7,6	43
OMT3-IE3 112M-4	4	1460		7,95	4,59	88,6	89,3	87,0	0,82	26,2	2,2	2,3	7,8	60
OMT3-IE3 132S-4	5,5	1470		10,7	6,16	89,6	89,2	87,7	0,83	35,7	2,0	2,3	7,9	73
OMT3-IE3 132M-4	7,5	1470		14,3	8,23	90,4	90,2	89,1	0,84	48,7	2,0	2,3	7,5	87
OMT3-IE3 160M-4	11	1470		20,4	11,8	91,4	91,0	90,0	0,85	71,5	2,2	2,3	7,7	136
OMT3-IE3 160L-4	15	1470		27,3	15,8	92,1	91,6	90,7	0,86	97,4	2,2	2,3	7,8	146
OMT3-IE3 180M-4	18,5	1475		33,5	19,4	92,6	92,4	91,4	0,86	120	2,0	2,3	7,8	191
OMT3-IE3 180L-4	22	1475		39,7	22,9	93,0	93,0	92,1	0,86	142	2,0	2,3	7,8	214
OMT3-IE3 200L-4	30	1480		53,8	31,1	93,6	93,3	92,4	0,86	194	2,0	2,3	7,8	265
OMT3-IE3 225S-4	37	1485		66,1	38,2	93,9	93,4	92,4	0,86	238	2,0	2,3	7,4	322
OMT3-IE3 225M1-4	45	1485		80,2	46,3	94,2	94,5	93,3	0,86	289	2,0	2,3	7,4	344

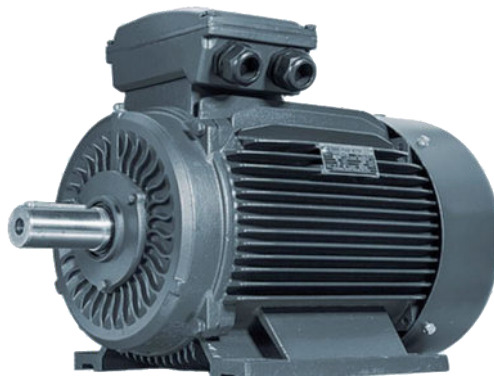

MOTOR TYPE	Rated power	Rated speed	Rated current			Efficiency IE3			Power factor	Nominal torque	Locked torque/ rated torque	Max. torque/ rated torque	Locked current/ rated current	Moment of inertia	Weight
	P_N	n_N	I_N			η			$\cos\phi$	M_N	M_R/M_N	M_{MAX}/M_N	I_R/I_N	J	m
	kW	min ⁻¹	A 230V	A 400V	A 690V	% 4/4	% 3/4	% 1/2	-	Nm	-	-	-	kgm ²	kg

4-pole motors – $n_s = 1500$ r/min - continued

OMT3-IE3 250M1-4	55	1485		97.6	56.3	94.6	94.8	93.6	0.86	354	2.0	2.3	7.4	450
OMT3-IE3 280S-4	75	1485		129	74.8	95.0	95.1	94.2	0.88	482	2.0	2.3	6.9	517
OMT3-IE3 280M-4	90	1485		155	89.5	95.2	95.4	94.5	0.88	579	2.0	2.3	6.9	562
OMT3-IE3 315S-4	110	1485		187	108	95.4	95.3	94.6	0.89	707	2.0	2.2	7.0	843
OMT3-IE3 315M-4	132	1485		224	129	95.6	95.5	94.4	0.89	849	2.0	2.2	7.0	923
OMT3-IE3 315L1-4	160	1485		271	156	95.8	95.7	94.8	0.89	1029	2.0	2.2	7.1	997
OMT3-IE3 315L2-4	200	1485		334	193	96.0	95.9	94.9	0.90	1286	2.0	2.2	7.1	1087
OMT3-IE3 355M2-4	250	1490		418	241	96.0	95.9	95.0	0.90	1602	2.0	2.2	7.1	1606
OMT3-IE3 355L2-4	315	1490		526	304	96.0	95.9	95.0	0.90	2019	2.0	2.2	7.1	1802

6-pole motors – $n_s = 1000$ r/min

OMT3-IE3 90S-6	0.75	955	3.35	1.93		78.9	79.6	77.7	0.71	7.50	2.0	2.1	6.0	25
OMT3-IE3 90L-6	1.1	955	4.65	2.69		81.0	81.8	79.8	0.73	11.0	2.0	2.1	6.0	31
OMT3-IE3 100L-6	1.5	955	6.23	3.6		82.5	83.2	81.5	0.73	15.0	2.0	2.1	6.5	38
OMT3-IE3 112M-6	2.2	970	8.82	5.09		84.3	84.6	82.9	0.74	21.7	2.0	2.1	6.6	47
OMT3-IE3 132S-6	3	970		6.84	3.95	85.6	86.3	84.8	0.74	29.5	2.0	2.1	6.8	60
OMT3-IE3 132M1-6	4	970		8.99	5.19	86.8	87.4	86.1	0.74	39.4	2.0	2.1	6.8	68
OMT3-IE3 132M2-6	5.5	970		12.0	6.93	88.0	88.4	87.4	0.75	54.1	2.0	2.1	7.0	76
OMT3-IE3 160M-6	7.5	980		15.4	8.9	89.1	89.5	88.3	0.79	73.1	2.0	2.1	7.0	115
OMT3-IE3 160L-6	11	980		22.0	12.7	90.3	90.8	89.5	0.80	107	2.0	2.1	7.2	151
OMT3-IE3 180L-6	15	980		29.3	16.9	91.2	91.4	90.2	0.81	146	2.0	2.1	7.3	218
OMT3-IE3 200L1-6	18.5	985		36.0	20.8	91.7	92.0	90.7	0.81	179	2.0	2.1	7.3	248
OMT3-IE3 200L2-6	22	985		42.5	24.5	92.2	92.5	91.1	0.81	213	2.0	2.1	7.4	272
OMT3-IE3 225M-6	30	985		56.2	32.4	92.9	93.2	92.2	0.83	291	2.0	2.1	6.9	378
OMT3-IE3 250M-6	37	990		68.1	39.3	93.3	93.4	92.6	0.84	357	2.0	2.1	7.1	397
OMT3-IE3 280S-6	45	990		81.6	47.1	93.7	93.6	92.8	0.85	434	2.0	2.0	7.3	489
OMT3-IE3 280M-6	55	990		98.1	56.6	94.1	94.2	93.2	0.86	531	2.0	2.0	7.3	550
OMT3-IE3 315S-6	75	990		136	78.5	94.6	94.5	93.3	0.84	723	2.0	2.0	6.6	763
OMT3-IE3 315M-6	90	990		161	93.0	94.9	94.8	93.5	0.85	868	2.0	2.0	6.7	868
OMT3-IE3 315L1-6	110	990		196	113	95.1	95.0	93.9	0.85	1061	2.0	2.0	6.7	974
OMT3-IE3 315L2-6	132	990		232	134	95.4	95.3	94.0	0.86	1273	2.0	2.0	6.8	1069
OMT3-IE3 355M1-6	160	990		281	162	95.6	95.5	94.2	0.86	1543	1.8	2.0	7.0	1411
OMT3-IE3 355M2-6	200	990		346	200	95.8	95.7	94.5	0.87	1929	1.8	2.0	7.0	1551
OMT3-IE3 355L-6	250	990		433	250	95.8	95.7	94.6	0.87	2412	1.8	2.0	6.8	1734



DIMENSIONAL DRAWING

Foot mounting B3

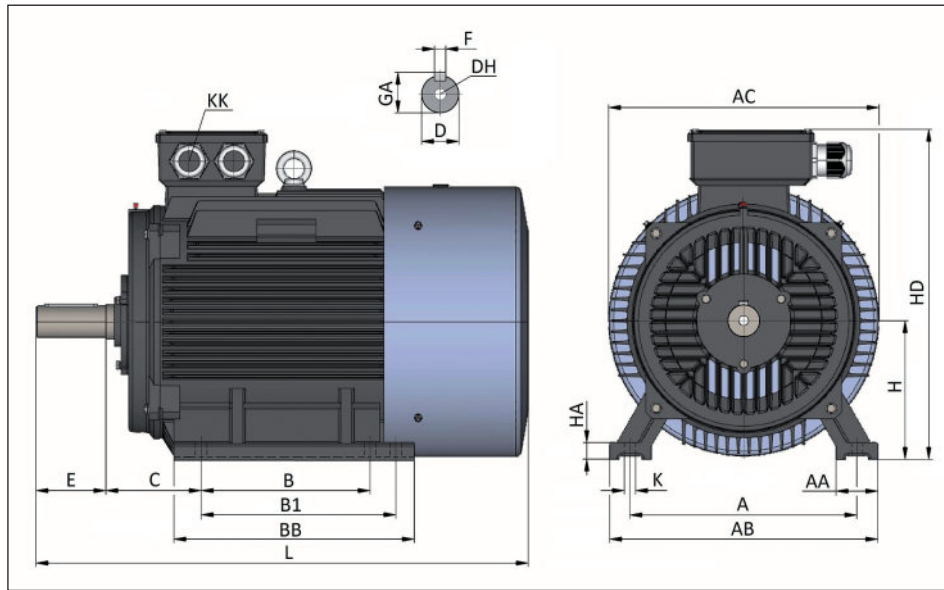

Foot & flange mounting B35

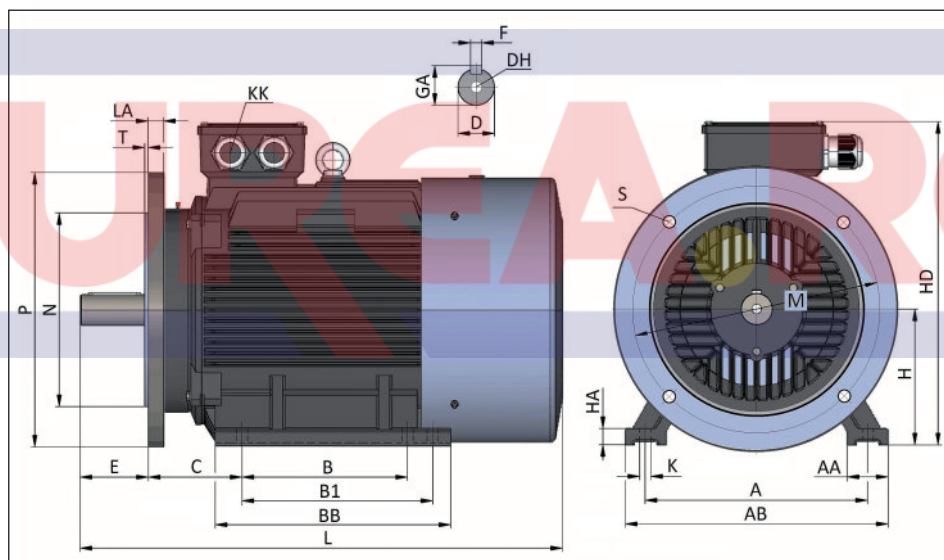

Flange mounting B5/V1

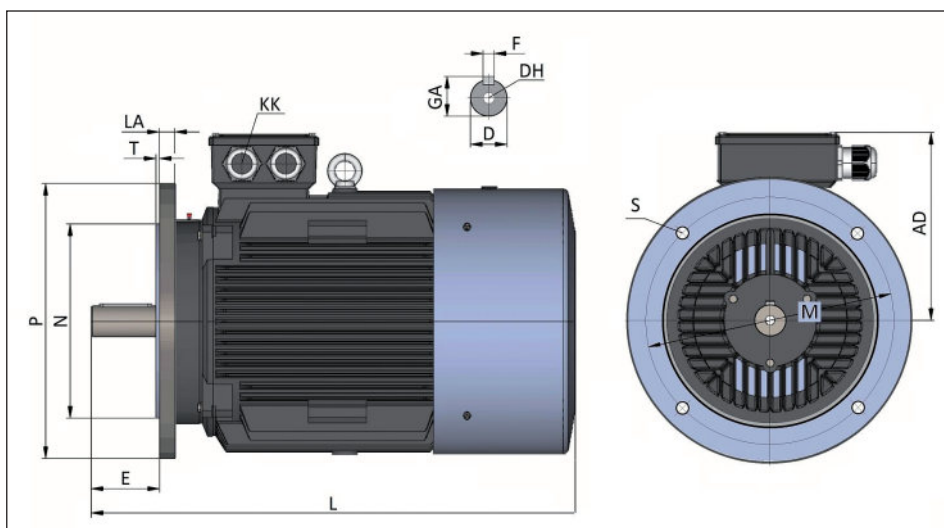

ASSEMBLY AND OVERALL DIMENSIONS

Frame size	2p	A	B	B1	C	D	E	F	GA	H	K	AA	AB	AC	AD	BB	DH	HA	HD	L	KK
OMT3-IE3 80	2-6	125	100	-	50	19	40	6	21.5	80	10	35	160	155	140	130	M6	12	220	300	M20x1.5
OMT3-IE3 90S	2-6	140	100	-	56	24	50	8	27	90	10	36	177	175	155	140	M8	12	245	327	M25x1.5
OMT3-IE3 90L	2-6	140	125	-	56	24	50	8	27	90	10	36	177	175	155	215	M8	12	245	385	M25x1.5
OMT3-IE3 100L	2-6	160	140	-	63	28	60	8	31	100	12	40	200	195	165	175	M10	14	265	403	M25x1.5
OMT3-IE3 112M	2-6	190	140	-	70	28	60	8	31	112	12	45	230	220	201	180	M10	15	313	430	M32x1.5
OMT3-IE3 132S	2-6	216	140	-	89	38	80	10	41	132	12	56	264	258	206	225	M12	18	338	504	M32x1.5
OMT3-IE3 132M	2-6	216	178	-	89	38	80	10	41	132	12	56	264	258	206	225	M12	18	338	504	M32x1.5
OMT3-IE3 160M	2-6	254	210	-	108	42	110	12	45	160	15	67	315	315	265	305	M16	20	425	650	M40x1.5
OMT3-IE3 160L	2-6	254	254	-	108	42	110	12	45	160	15	67	315	315	265	305	M16	20	425	650	M40x1.5
OMT3-IE3 180M	2-6	279	241	-	121	48	110	14	51.5	180	15	70	349	355	271	315	M16	22	451	700	M40x1.5
OMT3-IE3 180L	2-6	279	279	-	121	48	110	14	51.5	180	15	70	349	355	271	350	M16	22	451	740	M40x1.5
OMT3-IE3 200L	2-6	318	305	-	133	55	110	16	59	200	19	70	388	397	305	370	M20	25	505	776	M50x1.5
OMT3-IE3 225S	4-6	356	286	-	149	60	140	18	64	225	19	75	431	445	325	370	M20	28	550	815	M50x1.5
OMT3-IE3 225M	2	356	311	-	149	55	110	16	59	225	19	75	431	445	325	395	M20	28	550	825	M50x1.5
	4-6	356	311	-	149	60	140	18	64	225	19	75	435	445	325	395	M20	28	550	845	M50x1.5
OMT3-IE3 250M	2	406	349	-	168	60	140	18	64	250	24	80	485	485	365	445	M20	30	615	925	M63x1.5
	4-6	406	349	-	168	65	140	18	69	250	24	80	485	485	365	445	M20	30	615	925	M63x1.5
OMT3-IE3 280S	2	457	368	-	190	65	140	18	69	280	24	85	545	547	390	490	M20	35	670	998	M63x1.5
	4-6	457	368	-	190	75	140	20	79.5	280	24	85	545	547	390	490	M20	35	670	998	M63x1.5
OMT3-IE3 280M	2	457	419	-	190	65	140	18	69	280	24	85	550	547	390	540	M20	35	670	1046	M63x1.5
	4-6	457	419	-	190	75	140	20	79.5	280	24	85	550	547	390	540	M20	35	670	1046	M63x1.5
OMT3-IE3 315S	2	508	406	-	216	65	140	18	69	315	28	120	630	620	540	570	M20	45	855	1190	M63x1.5
	4-6	508	406	-	216	80	170	22	85	315	28	120	630	620	540	570	M20	45	855	1220	M63x1.5
OMT3-IE3 315M.L	2	508	457	508	216	65	140	18	69	315	28	120	630	620	540	680	M20	45	855	1295	M63x1.5
	4-6	508	457	508	216	80	170	22	85	315	28	120	630	620	540	680	M20	45	855	1325	M63x1.5
OMT3-IE3 355M	2	610		560	254	75	140	20	79.5	355	28	116	726	700	647	750	M20	52	1002	1484	M63x1.5
	4-6	610		560	254	95	170	25	100	355	28	116	726	700	647	750	M20	52	1002	1514	M63x1.5
OMT3-IE3 355L	2	610		630	254	75	140	20	79.5	355	28	116	726	700	647	750	M20	52	1002	1484	M63x1.5
	4-6	610		630	254	95	170	25	100	355	28	116	726	700	647	750	M20	52	1002	1514	M63x1.5

Dimensions of flanges

Frame size	B5						B14L					B14S				
	M	N	P	S	T	LA	M	N	P	S	T	M	N	P	S	T
OMT3-80	165	130	200	4x Ø12	3.5	12	130	110	160	4x M8	3.5	100	80	120	4x M6	3.0
OMT3-90	165	130	200	4x Ø12	3.5	12	130	110	160	4x M8	3.5	115	95	140	4x M8	3.0
OMT3-100	215	180	250	4x Ø15	4	13	165	130	200	4x M10	3.5	130	110	160	4x M8	3.5
OMT3-112	215	180	250	4x Ø15	4	14	165	130	200	4x M10	3.5	130	110	160	4x M8	3.5
OMT3-132	265	230	300	4x Ø15	4	14	215	180	250	4x M12	4.0	165	130	200	4x M10	3.5
OMT3-160	300	250	350	4x Ø19	5	15										
OMT3-180	300	250	350	4x Ø19	5	15										
OMT3-200	350	300	400	4x Ø19	5	17										
OMT3-225	400	350	450	8x Ø19	5	20										
OMT3-250	500	450	550	8x Ø19	5	22										
OMT3-280	500	450	550	8x Ø19	6	22										
OMT3-315	600	550	660	8x Ø24	6	22										
OMT3-355	740	680	800	8x Ø24	6	25										

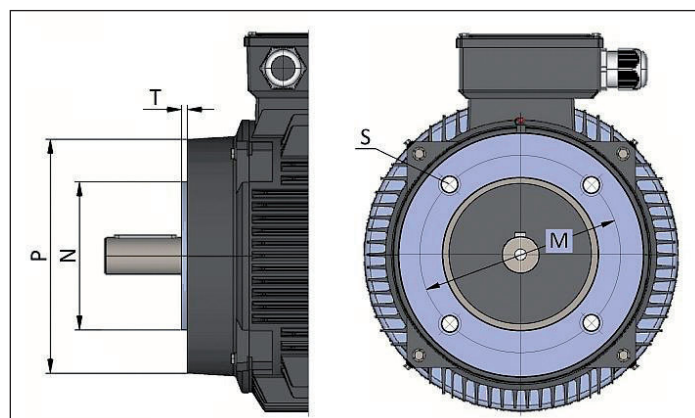

Comments:

- 1) Flange motors mounted in position B5 are available for frame sizes 80 to 280.
- 2) Flange motors mounted in position V1 can be supplied with an additional small protective roof.
- 3) Flange motors B14S and B14L are available only for frame sizes 80 to 132.

Note: The manufacturer reserves the right to change the operating parameters and overall dimensions as the construction is modernized.

MOTOR TYPE	Rated power	Rated speed	Rated current			Efficiency IE4			Power factor	Nominal torque	Locked torque/rated torque	Max. torque /rated torque	Locked current /rated current	Moment of inertia	Weight
	P _N	n _N	I _N			%			cos φ	M _N	M _R /M _N	M _{MX} /M _N	I _R /I _N	j	m
	kW	min ⁻¹	A 230V	A 400V	A 690V	% 4/4	% 3/4	% 1/2	-	Nm	-	-	-	kgm ²	kg

2-pole motors n _s = 3000 r/min															
OMT3-IE4 80 1-2	0.75	2890	2.8	1.6		83.5	83.8	82.1	0.83	2.48	2.2	2.3	8.5	0.00115	24
OMT3-IE4 80 2-2	1.1	2890	3.8	2.2		85.2	85.9	84.5	0.83	3.63	2.2	2.3	8.5	0.00149	25
OMT3-IE4 90S-2	1.5	2890	5.0	2.9		86.5	87.7	86.0	0.85	4.96	2.2	2.3	9.0	0.00231	27
OMT3-IE4 90L1-2	2.2	2895	7.3	4.2		88.0	88.6	87.3	0.86	7.26	2.2	2.3	9.0	0.00297	32.5
OMT3-IE4 100L1-2	3	2895		5.6	3.2	89.1	89.8	88.5	0.87	9.90	2.2	2.3	9.5	0.00475	41
OMT3-IE4 112M-2	4	2915		7.3	4.2	90.0	90.4	89.2	0.88	13.10	2.2	2.3	9.5	0.00659	64
OMT3-IE4 132S1-2	5.5	2940		9.9	5.7	90.9	91.2	90.1	0.88	17.87	2.0	2.3	9.5	0.01454	75
OMT3-IE4 132S2-2	7.5	2940		13.3	7.7	91.7	92.3	91.0	0.89	24.36	2.0	2.3	9.5	0.01707	81
OMT3-IE4 160M1-2	11	2950		19.3	11.2	92.6	92.8	91.2	0.89	35.61	2.0	2.3	9.5	0.07108	129
OMT3-IE4 160M2-2	15	2950		26.1	15.1	93.3	93.6	92.5	0.89	48.56	2.0	2.3	9.5	0.0801	140
OMT3-IE4 160L-2	18.5	2950		32	18.5	93.7	93.9	92.7	0.89	59.89	2.0	2.3	9.5	0.0923	165
OMT3-IE4 180M-2	22	2960		38	22.0	94.0	94.2	93.1	0.89	70.98	2.0	2.5	9.5	0.0920	208
OMT3-IE4 200L1-2	30	2970		51.5	29.8	94.5	94.7	93.3	0.89	96.46	2.0	2.3	9.0	0.1842	265
OMT3-IE4 200L2-2	37	2970		63.3	36.6	94.8	95.0	93.7	0.89	119.0	2.0	2.3	9.0	0.1856	283
OMT3-IE4 225M1-2	45	2970		76.8	44.4	95.0	94.9	93.6	0.89	144.7	2.0	2.3	9.0	0.3400	366
OMT3-IE4 250M1-2	55	2980		93.6	54.1	95.3	95.5	93.9	0.89	176.3	2.0	2.3	9.0	0.4756	404
OMT3-IE4 280S-2	75	2980		127	73.4	95.6	95.4	94.5	0.89	240.4	1.8	2.3	8.5	1.112	548
OMT3-IE4 280M-2	90	2980		152	87.9	95.8	96.0	95.1	0.89	288.4	1.8	2.3	8.5	1.1723	595
OMT3-IE4 315S-2	110	2980		186	108	96.0	96.1	95.3	0.89	352.5	1.8	2.3	8.5	1.5195	875
OMT3-IE4 315M-2	132	2980		223	129	96.2	96.3	95.4	0.89	423.0	1.8	2.3	8.5	2.1486	965
OMT3-IE4 315L1-2	160	2980		269	156	96.3	96.2	95.4	0.89	512.8	1.8	2.2	8.5	2.4408	1040
OMT3-IE4 315L2-2	200	2980		336	194	96.5	96.4	95.5	0.89	640.9	1.8	2.2	8.5	2.7014	1132
OMT3-IE4 355M-2	250	2980		411	238	96.5	96.4	95.5	0.91	801.2	1.6	2.2	8.5	3.3957	1675
OMT3-IE4 355L-2	315	2980		518	299	96.5	96.4	95.5	0.91	1009.5	1.6	2.2	8.5	3.9597	1870

4-pole motors n _s = 1500 r/min															
OMT3-IE4 80 2-4	0.75	1430	2.9	1.7		85.7	85.9	84.5	0.74	5.01	2.3	2.3	8.5	0.0028	26
OMT3-IE4 90S-4	1.1	1445	4.2	2.4		87.2	87.8	85.9	0.75	7.27	2.3	2.3	8.5	0.0034	27
OMT3-IE4 90L1-4	1.5	1445	5.5	3.2		88.2	89.0	87.6	0.76	9.91	2.3	2.3	9.0	0.0044	30.5
OMT3-IE4 100L1-4	2.2	1460	7.8	4.5		89.5	90.0	88.5	0.79	14.39	2.3	2.3	9.0	0.0057	42
OMT3-IE4 100L2-4	3	1460		6	3.5	90.4	90.8	89.7	0.80	19.62	2.3	2.3	9.5	0.0106	47
OMT3-IE4 112M-4	4	1460		7.9	4.6	91.1	91.8	90.3	0.80	26.16	2.2	2.3	9.5	0.0146	63
OMT3-IE4 132S-4	5.5	1470		10.8	6.2	91.9	92.3	91.2	0.80	35.73	2.0	2.3	9.5	0.0318	86
OMT3-IE4 132M-4	7.5	1470		14.4	8.3	92.6	93.2	92.2	0.81	48.72	2.0	2.3	9.5	0.0410	96
OMT3-IE4 160M-4	11	1470		20.5	11.8	93.3	93.6	92.7	0.83	71.46	2.2	2.3	9.5	0.1097	139
OMT3-IE4 160L-4	15	1470		27.4	15.8	93.9	94.2	93.2	0.84	97.45	2.0	2.3	9.5	0.1432	163
OMT3-IE4 180M-4	18.5	1475		33.3	19.2	94.2	94.5	93.6	0.85	119.8	2.2	2.3	9.5	0.1712	199
OMT3-IE4 180L-4	22	1475		39.5	22.8	94.5	94.8	93.9	0.85	142.4	2.0	2.3	9.5	0.2103	224
OMT3-IE4 200L-4	30	1480		53.7	31.0	94.9	94.7	93.7	0.85	193.6	2.0	2.3	9.0	0.3204	283
OMT3-IE4 225S-4	37	1485		66	38.2	95.2	95.3	94.5	0.85	237.9	2.0	2.3	9.0	0.5331	350
OMT3-IE4 225M1-4	45	1485		80.1	46.3	95.4	95.7	94.5	0.85	289.4	2.0	2.3	9.0	0.6233	380

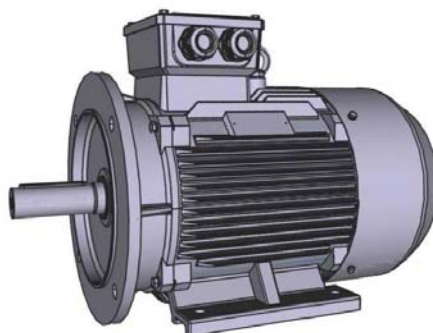

MOTOR TYPE	Rated power	Rated speed	Rated current			Efficiency IE4			Power factor	Nominal torque	Locked torque /rated torque	Max. torque /rated torque	Locked current /rated current	Moment of inertia	Weight
	P _N	n _n	I _N			η			cos φ	M _N	M _r /M _N	M _{mx} /M _N	I _r /I _N	j	m
	kW	min ⁻¹	A 230V	A 400V	A 690V	% 4/4	3/4	1/2	-	Nm	-	-	-	kgm ²	kg

4-pole motors n _s = 1500 r/min - continued															
OMT3-IE4 250M1-4	55	1485		96.5	55.8	95.7	95.9	94.7	0.86	353.7	2.0	2.3	9.0	0.8428	440
OMT3-IE4 280S-4	75	1485		130	75.1	96.0	96.1	95.2	0.87	482.3	2.0	2.3	8.5	2.1552	610
OMT3-IE4 280M-4	90	1485		154	89.0	96.1	96.3	95.4	0.88	578.8	2.0	2.3	8.5	2.6009	693
OMT3-IE4 315S-4	110	1485		185	107	96.3	96.2	95.5	0.89	707.4	1.8	2.2	8.5	3.6771	935
OMT3-IE4 315M-4	132	1485		222	128	96.4	96.3	95.5	0.89	848.9	1.8	2.2	8.5	4.2719	1035
OMT3-IE4 315L1-4	160	1485		266	154	96.6	96.5	95.6	0.90	1029	1.8	2.2	8.5	4.6667	1135
OMT3-IE4 315L2-4	200	1485		332	192	96.7	96.6	95.6	0.90	1286	1.8	2.2	8.5	5.3447	1210
OMT3-IE4 355M-4	250	1490		415	240	96.7	96.6	95.7	0.90	1602	1.8	2.2	8.5	7.3369	1650
OMT3-IE4 355L-4	315	1490		522	302	96.7	96.6	95.7	0.90	2019	1.8	2.2	8.5	9.2714	1805
OMT3-IE4 355L2-4	355	1490		589	341	96.7	96.6	95.7	0.90	2275	1.8	2.2	8.5	10.350	2015

6-pole motors n _s = 1000 r/min															
OMT3-IE4 90S-6	0.75	955	3.3	1.9		82.7	83.4	81.4	0.70	7.50	2.1	2.1	7.5	0.0044	26.5
OMT3-IE4 90L-6	1.1	955	4.7	2.7		84.5	85.3	83.2	0.70	11.00	2.1	2.1	7.5	0.0060	32
OMT3-IE4 100L-6	1.5	955	6.2	3.6		85.9	86.6	84.9	0.71	15.00	2.1	2.1	7.5	0.0123	41
OMT3-IE4 112M-6	2.2	970	8.8	5.1		87.4	87.7	85.9	0.71	21.66	2.1	2.1	7.5	0.0172	51
OMT3-IE4 132S-6	3	970		6.9	4.0	88.6	89.3	87.8	0.71	29.54	2.0	2.1	7.5	0.0361	67
OMT3-IE4 132M1-6	4	970		9	5.2	89.5	90.1	88.8	0.72	39.38	2.0	2.1	8.0	0.0448	76
OMT3-IE4 132M2-6	5.5	970		12.2	7.1	90.5	90.9	89.9	0.72	54.15	2.0	2.1	8.0	0.0555	84
OMT3-IE4 160M-6	7.5	980		16.2	9.4	91.3	91.7	90.5	0.73	73.09	2.0	2.1	8.0	0.0971	128
OMT3-IE4 160L-6	11	980		22.3	12.9	92.3	92.8	91.5	0.77	107.2	2.0	2.1	8.5	0.1433	168
OMT3-IE4 180L-6	15	980		29.1	16.8	92.9	93.1	91.9	0.80	146.2	2.0	2.1	8.5	0.2611	220
OMT3-IE4 200L1-6	18.5	985		35.7	20.6	93.4	93.7	92.4	0.80	179.4	2.0	2.1	8.5	0.3813	268
OMT3-IE4 200L2-6	22	985		41.8	24.2	93.7	94.0	92.6	0.81	213.3	2.0	2.1	8.5	0.4326	290
OMT3-IE4 225M-6	30	985		56.1	32.4	94.2	94.5	93.5	0.82	290.9	2.0	2.1	8.3	0.6411	403
OMT3-IE4 250M-6	37	990		68.1	39.4	94.5	94.6	93.8	0.83	356.9	2.0	2.1	8.3	0.9918	426
OMT3-IE4 280S-6	45	990		82.6	47.7	94.8	94.7	93.9	0.83	434.1	2.0	2.0	8.5	1.9522	533
OMT3-IE4 280M-6	55	990		99.4	57.5	95.1	95.2	94.2	0.84	530.6	2.0	2.0	8.5	2.3851	596
OMT3-IE4 315S-6	75	990		135	78	95.4	95.3	94.1	0.84	723.5	1.6	2.0	8.0	4.6521	803
OMT3-IE4 315M-6	90	990		160	93	95.6	95.5	94.2	0.85	868.2	1.6	2.0	8.0	5.3948	912
OMT3-IE4 315L1-6	110	990		195	113	95.8	95.7	94.6	0.85	1061	1.6	2.0	8.0	6.1430	1020
OMT3-IE4 315L2-6	132	990		231	134	96.0	95.9	94.6	0.86	1273	1.6	2.0	8.0	6.9043	1115
OMT3-IE4 355M1-6	160	990		279	161	96.2	96.1	94.8	0.86	1543	1.6	2.0	8.0	10.685	1505
OMT3-IE4 355M2-6	200	990		349	202	96.3	96.2	95.0	0.86	1929	1.6	2.0	8.0	11.703	1645
OMT3-IE4 355L-6	250	990		435	251	96.5	96.4	95.3	0.86	2412	1.6	2.0	8.0	13.941	1825

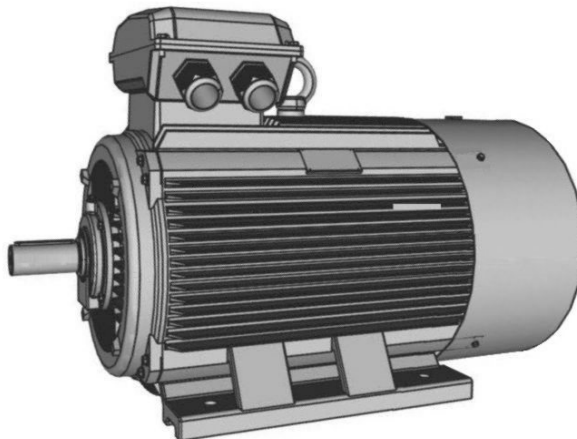

ASSEMBLY AND OVERALL DIMENSIONS

Foot mounting B3

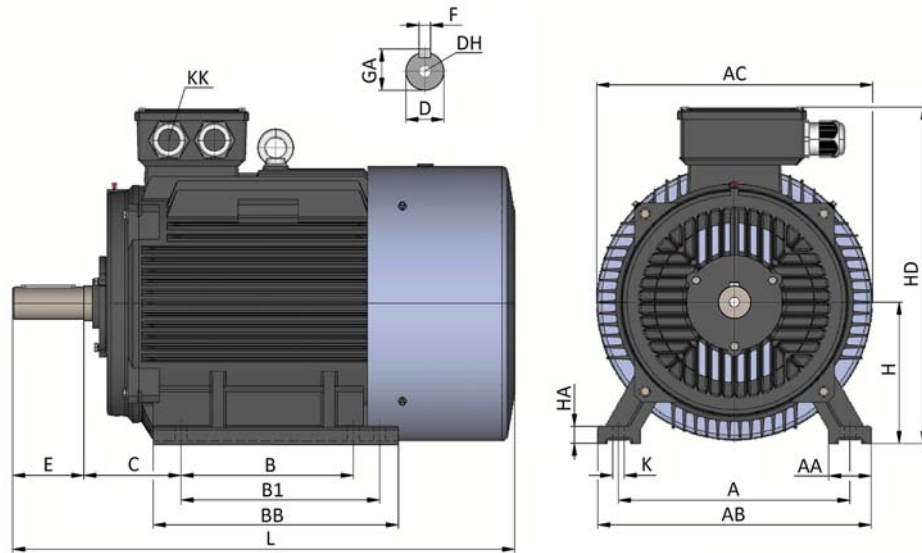

Foot & flange mounting B35

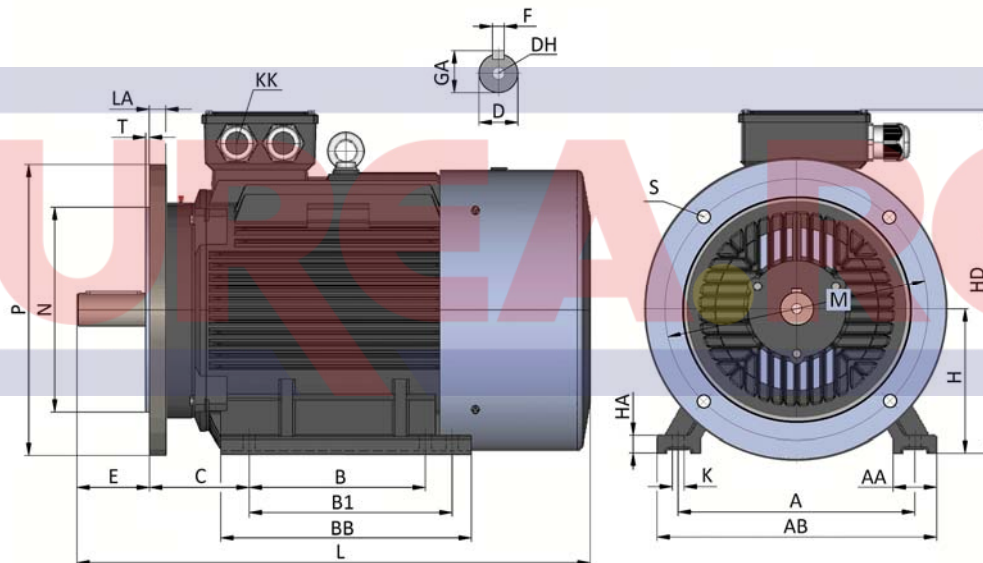

Flange mounting B5/V1

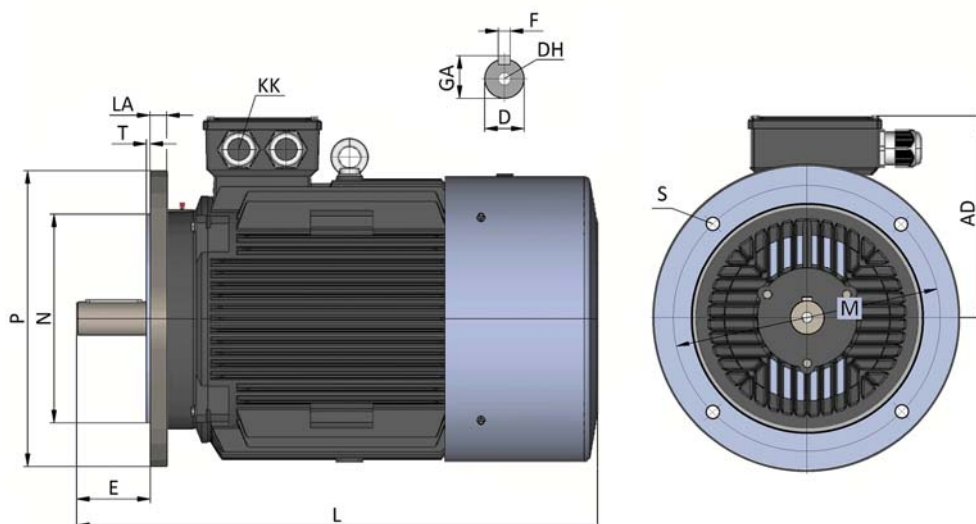

ASSEMBLY AND OVERALL DIMENSIONS

Motor type	2p	A	B	C	D	E	F	GA	H	K	AA	AB	AC	AD	BB	DH	HA	HD	L	KK
OMT3-IE4 80	2-6	125	100	50	19	40	6	21.5	80	10	35	165	158	140	130	M6x16	12	220	300	M20x1.5
OMT3-IE4 90S	2-6	140	100	56	24	50	8	27	90	10	36	180	177	160	140	M8x19	12	255	350	M25x1.5
OMT3-IE4 90L	2-6	140	125	56	24	50	8	27	90	10	36	180	177	160	165	M8x19	12	255	385	M25x1.5
OMT3-IE4 100L	2-6	160	140	63	28	60	8	31	100	12	40	205	198	172	175	M10x22	14	270	400	M25x1.5
OMT3-IE4 112M	2-6	190	140	70	28	60	8	31	112	12	45	226	235	193	180	M10x22	15	300	425	M32x1.5
OMT3-IE4 132S	2-6	216	140	89	38	80	10	41	132	12	56	262	293	225	225	M12x28	18	349	502	M32x1.5
OMT3-IE4 132M	2-6	216	178	89	38	80	10	41	132	12	56	262	293	225	225	M12x28	18	349	533	M32x1.5
OMT3-IE4 160M	2-6	254	210	108	42	110	12	45	160	15	65	320	315	255	304	M16x36	20	420	660	M40x1.5
OMT3-IE4 160L	2-6	254	254	108	42	110	12	45	160	15	65	320	315	255	334	M16x36	20	420	730	M40x1.5
OMT3-IE4 180M	2-6	279	241	121	48	110	14	51.5	180	15	70	355	355	280	349	M16x36	22	455	740	M40x1.5
OMT3-IE4 180L	2-6	279	279	121	48	110	14	51.5	180	15	70	355	355	280	403	M16x36	22	455	810	M40x1.5
OMT3-IE4 200L	2-6	318	305	133	55	110	16	59	200	19	70	395	397	305	370	M20x42	25	505	852	M50x1.5
OMT3-IE4 225S	4-6	356	286	149	60	140	18	64	225	19	75	435	445	335	370	M20x42	28	560	874	M50x1.5
OMT3-IE4 225M	2	356	311	149	55	110	16	59	225	19	75	435	445	335	395	M20x42	28	560	890	M50x1.5
	4-6	356	311	149	60	140	18	64	225	19	75	435	445	335	395	M20x42	28	560	915	M50x1.5
OMT3-IE4 250M	2	406	349	168	60	140	18	64	250	24	80	490	485	370	455	M20x42	30	615	985	M63x1.5
	4-6	406	349	168	65	140	18	69	250	24	80	490	485	370	455	M20x42	30	615	985	M63x1.5
OMT3-IE4 280S	2	457	368	190	65	140	18	69	280	24	85	550	547	410	490	M20x42	35	680	1045	M63x1.5
	4-6	457	368	190	75	140	20	79.5	280	24	85	550	547	410	490	M20x42	35	680	1045	M63x1.5
OMT3-IE4 280M	2	457	419	190	65	140	18	69	280	24	85	550	547	410	540	M20x42	35	680	1095	M63x1.5
	4-6	457	419	190	75	140	20	79.5	280	24	85	550	547	410	540	M20x42	35	680	1095	M63x1.5
OMT3-IE4 315S	2	508	406	216	65	140	18	69	315	28	120	635	620	530	575	M20x42	45	845	1185	M63x1.5
	4-6	508	406	216	80	170	22	85	315	28	120	635	620	530	575	M20x42	45	845	1220	M63x1.5
OMT3-IE4 315M	2	508	457	216	65	140	18	69	315	28	120	635	620	530	685	M20x42	45	845	1290	M63x1.5
	4-6	508	457	216	80	170	22	85	315	28	120	635	620	530	685	M20x42	45	845	1325	M63x1.5
OMT3-IE4 315L	2	508	508	216	65	140	18	69	315	28	120	635	620	530	685	M20x42	45	845	1290	M63x1.5
	4-6	508	508	216	80	170	22	85	315	28	120	635	620	530	685	M20x42	45	845	1325	M63x1.5
OMT3-IE4 355M	2	610	560	254	75	140	20	79.5	355	28	120	730	698	655	750	M20x42	52	1010	1500	M63x1.5
	4-6	610	560	254	95	170	25	100	355	28	120	730	698	655	750	M20x42	52	1010	1530	M63x1.5
OMT3-IE4 355L	2	610	630	254	75	140	20	79.5	355	28	120	730	698	655	750	M20x42	52	1010	1500	M63x1.5
	4-6	610	630	254	95	170	25	100	355	28	120	730	698	655	750	M20x42	52	1010	1530	M63x1.5

Dimensions of flanges

Motor type	B5						B14L					B14S				
	M	N	P	S	T	LA	M	N	P	S	T	M	N	P	S	T
OMT3-IE4 80	165	130	200	4x Ø12	3.5	12	130	110	160	4x M8	3.5	100	80	120	4x M6	3.0
OMT3-IE4 90	165	130	200	4x Ø12	3.5	12	130	110	160	4x M8	3.5	115	95	140	4x M8	3.0
OMT3-IE4 100	215	180	250	4x Ø15	4	13	165	130	200	4x M10	3.5	130	110	160	4x M8	3.5
OMT3-IE4 112	215	180	250	4x Ø15	4	14	165	130	200	4x M10	3.5	130	110	160	4x M8	3.5
OMT3-IE4 132	265	230	300	4x Ø15	4	14	215	180	250	4x M12	4.0	165	130	200	4x M10	3.5
OMT3-IE4 160	300	250	350	4x Ø19	5	15										
OMT3-IE4 180	300	250	350	4x Ø19	5	15										
OMT3-IE4 200	350	300	400	4x Ø19	5	17										
OMT3-IE4 225	400	350	450	8x Ø19	5	20										
OMT3-IE4 250	500	450	550	8x Ø19	5	22										
OMT3-IE4 280	500	450	550	8x Ø19	6	22										
OMT3-IE4 315	600	550	660	8x Ø24	6	22										
OMT3-IE4 355	740	680	800	8x Ø24	6	25										

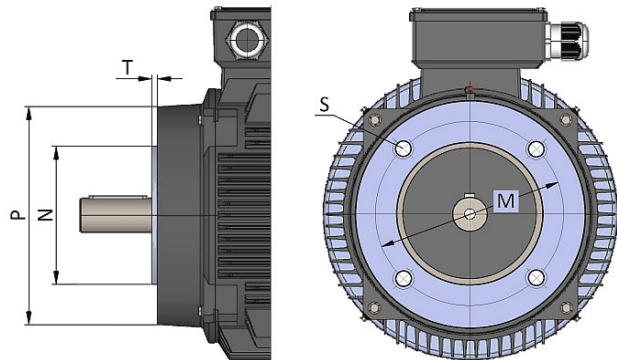

Comments:

- 1) Flange motors mounted in position B5 are available for frame sizes 80 to 280.
- 2) Flange motors mounted in position V1 can be supplied with an additional small protective roof.
- 3) Flange motors B14S and B14L are available only for frame sizes 80 to 132.

Note: The manufacturer reserves the right to change the operating parameters and overall dimensions as the construction is modernized.

APPLICATION:

In variable-speed electric motors (e.g. with inverter supply), when the speed is reduced below the rated speed, the performance of the standard shaft-mounted fan is reduced, resulting in a deterioration of their cooling conditions.

For this purpose, in all constant-torque drives (e.g. presses, conveyor belts, centrifuges, gearboxes, etc.), where a constant torque on the main motor shaft [T=f(n)=const.] over the entire or wide speed control range is required, extraneous (forced) ventilation units are used to ensure a constant cooling capacity, regardless of the main motor speed.

In drives with so-called quadratic load characteristics [T=f(n)²] (e.g. pumps, fans, etc.), where the load torque varies with the square of the speed, i.e. decreases when the speed is reduced, a self-cooled motor is sufficient.

CHARACTERISTICS

- 1-phase power supply 230V/50Hz
- degree of protection IP40
- insulation class F
- working temperature -20..+40°C
- fan with ball bearings
- separate terminal box IP55
- assembly in place of the standard cowl, after removing the ventilator from the motor shaft - no need to cut off the shaft
- other designs, dimensions, etc. available on request
- design according to EN 60034-1; IEC 34-1

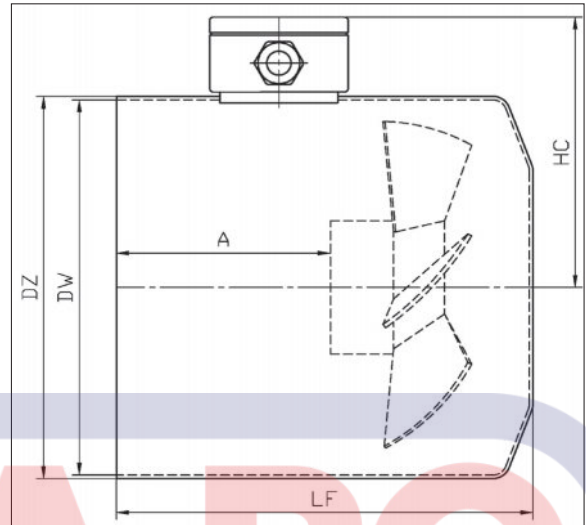

Type/size	Parameters						Dimensions				
	Air expeance	Power	Voitage	Current	Rotation speed	Weight	DZ	DW	LF	A	HC
	m ³ /h	W	V	A	r/min	kg	mm				
R-63A	144	16	230	0,11	2700	0,9	125	123	150	88	100
R-71A	144	16	230	0,11	2700	1,0	138	136	160	95	105
R-80A	272	36	230	0,29	2650	1,6	157	155	175	95	115
R-90A	255	59	230	0,24	2350	1,8	176	174	190	110	125
R-100A	255	59	230	0,24	2350	2,0	196	194	190	110	135
R-112A	344	25	230	0,11	2800	2,2	220	218	175	105	146
R-132A	568	72	230	0,50	2350	3,4	259	257	200	125	195
R-160A	1440	56	230	0,24	2100	4,8	316	314	255	160	225

Notes:

1. As standard, the kits do not have holes in the cowl for attachment to the main engine fuselage. The user should make them himself depending on the design of his engine.
2. The main electric motor should only be started and run when the external cooling fan is energised.

MODIFICATION OF MOTORS

We carry out the following modifications to electric motors

- assembly of external cooling
- encoder installation
- installation of heaters
- motor sealing to IP56, IP65
- installation of vibration and temperature sensors
- other



EMPOWERING THE FUTURE OF INDUSTRY

 **OMEC MOTORS**

www.omecmotors.com